

2  
0  
2  
1

# ELECTRICAL INSPECTIONS

## SASKATCHEWAN INTERPRETATIONS

Based on the 2021  
Canadian Electrical Code

Effective November 1, 2021  
Amended September 1, 2023   
V4.0



**Technical  
Safety Authority**  
of Saskatchewan

## Δ PREFACE AND SCOPE

The Canadian Electrical Code, Part I, Twenty-Fifth Edition, as interpreted by these requirements, issued under Section 5 of *The Electrical Inspection Act, 1993*, shall govern the workmanship and all other matters pertaining to electrical equipment and the installation of electrical equipment in or upon any land, buildings, structures, and premises. All previously issued bulletins are superseded by these interpretations.

This document contains supplementary information to clarify the requirements of the 25th edition of the Canadian Electrical Code (CEC), and by their inclusion herein are adopted as requirements under Section 5 of *The Electrical Inspection Act, 1993*.

New or principally changed text is indicated by the blue Delta symbol (Δ) displayed in the Margin, further changes are color coded to the Appendix of Amendments found at the end of the publication. A change to the new TSASK e-mail address only may not be indicated with a symbol. The Acts and Regs have also been updated to reflect the new corporation and management structure.

## REPORT OF ACCIDENT

*The Electrical Inspection Act, 1993* c.E-6.3 s.27 requires:

“Where an accident involving an electrical installation or electrical equipment occurs and results in a death or injury of a person or in a fire or an explosion, the contractor or the contractor’s agent or the owner of the electrical equipment or the owner’s agent shall immediately notify the Chief Electrical Inspector, stating the precise location of the accident, its general nature and results”.

## Investigation of Accident

*The Electrical Inspection Act, 1993* c.E-6.3 s.28 requires:

The accident site is to be preserved, “no part of any electrical plant or electrical equipment involved is to be removed or its position altered by any person”, “until the written permission of an Inspector has been obtained”.

**FOR A FIRE OR ACCIDENT INVOLVING ELECTRICAL ENERGY CAUSING INJURY OR DEATH CALL:  
1-866-530-8599, OPTION 1.**

**AFTER HOURS CALL THE CHIEF ELECTRICAL INSPECTOR OR ELECTRICAL MANAGERS  
[FOUND ON THE ELECTRICAL INSPECTIONS CONTACT LISTING](#)**



## Contents

PREFACE AND SCOPE .....	1
REPORT OF ACCIDENT .....	1
Investigation of Accident .....	1
WEBSITE INFORMATION .....	12
BOND NOTICE ADMINISTRATION FEES .....	12
UNREPORTED WORK PENALTY – ELECTRICAL INSPECTION REGULATION .....	12
ENERGIZATION STICKERS .....	12
ELECTRICAL INSPECTIONS REGISTERED ELECTRICAL CONTRACTOR PROGRAM .....	13
JOURNEYMAN LICENCE (SEE THE ELECTRICAL LICENSING ACT E-7.2) .....	13
EMPLOYER’S LICENCE (SEE THE ELECTRICAL LICENSING ACT E-7.2) .....	13
SECTION 2 – GENERAL RULES .....	14
2-004 - PERMIT .....	14
2-004 - Permits for low voltage and extra low voltage installations .....	15
2-004 - PERMITS FOR SIGNS AND OUTLINE LIGHTING .....	16
2-004 - PERMITS FOR CUSTOMER SUPPLIED EQUIPMENT AND SKIDS .....	16
2-012 - INSPECTION REQUEST REQUIRED .....	16
2-014 - PLANS AND SPECIFICATIONS .....	16
2-022 - RENOVATIONS OF EXISTING INSTALLATIONS .....	20
2-024 - USE OF APPROVED EQUIPMENT (SEE ALSO FIELD INSPECTION AGENCIES AND CERTIFICATION BODIES BOOKLET) .....	22
2-024 - USE OF APPROVED EQUIPMENT - EXCEPTIONS .....	23
LIQUID-FILLED TRANSFORMERS .....	23
HV DOWNHOLE ESP’S (ELECTRICAL SUBMERSIBLE PUMPS) .....	24
2-030 - DEVIATION OR POSTPONEMENT .....	25
2-106 - REBUILT EQUIPMENT .....	25
2-200 - PROTECTION OF EQUIPMENT .....	26
2-300 - GENERAL REQUIREMENTS FOR MAINTENANCE AND OPERATION .....	27
2-328 - ELECTRICAL EQUIPMENT NEAR COMBUSTIBLE GAS EQUIPMENT .....	27
2-400 - ENCLOSURES, TYPE, DESIGNATION, AND USE (SEE APPENDIX B) .....	27
(SEE ALSO 12-610) .....	27
SECTION 4 – CONDUCTORS .....	28
D8 TABLES WITH 75° CALCULATIONS .....	28
D9 TABLES WITH 75° CALCULATIONS .....	29



D10 TABLES WITH 75° CALCULATIONS .....	30
D11 TABLES WITH 75° CALCULATIONS .....	31
4-004 – AMPACITY OF WIRES AND CABLES (SEE APPENDIX B).....	32
4-006 - TEMPERATURE LIMITATIONS (SEE APPENDIX B) .....	32
4-008 - INDUCED VOLTAGES AND CURRENTS IN METAL ARMOUR OR SHEATHS OF .....	33
SINGLE CONDUCTOR CABLES (SEE APPENDIX B) .....	33
4-022 - INSTALLATION OF IDENTIFIED CONDUCTORS (SEE APPENDIX B).....	34
4-032(3) - IDENTIFICATION OF INSULATED CONDUCTORS.....	34
SECTION 6 – SERVICES AND SERVICE EQUIPMENT .....	35
6-104 - NUMBER OF CONSUMER’S SERVICES PERMITTED IN OR ON A BUILDING.....	35
6-112 - SUPPORT FOR THE ATTACHMENT OF OVERHEAD SUPPLY OR CONSUMER’S SERVICE CONDUCTORS OR CABLES (SEE APPENDIX B) .....	35
6-200(1) - SERVICE EQUIPMENT - SINGLE BREAKER SERVICE EQUIPMENT .....	35
6-200(2) - SERVICE EQUIPMENT – DUAL-LUG METER SOCKETS (SEE 6-104).....	35
6-206 - CONSUMER’S SERVICE EQUIPMENT LOCATION .....	36
6-208 - CONSUMER’S SERVICE CONDUCTORS’ LOCATION - UNDER HOUSE TRAILER/MOBILE HOMES	37
6-212 -WIRING SPACE IN ENCLOSURES .....	37
6-300 - INSTALLATION OF UNDERGROUND CONSUMER’S SERVICE CONDUCTORS.....	37
6-312 - CONDENSATION IN CONSUMER’S SERVICE RACEWAY.....	38
6-404 - ENCLOSURES FOR INSTRUMENT TRANSFORMERS.....	38
6-408(1)(f) – LOCATION OF METERS (NOTE DELETED) .....	38
SECTION 8 – CIRCUIT LOADING AND DEMAND FACTORS.....	39
8-102 - VOLTAGE DROP.....	39
8-104 - MAXIMUM CIRCUIT LOADING (SEE APPENDIX B).....	40
8-104(3)(A) -WATER HEATERS .....	40
8-106 - USE OF DEMAND FACTORS.....	40
SECTION 10 – GROUNDING AND BONDING.....	41
10-000 - SCOPE .....	41
10-004 - SPECIAL TERMINOLOGY.....	41
10-100 & 10-500 - CURRENT OVER GROUNDING AND BONDING CONDUCTORS.....	41
10-102 - GROUNDING ELECTRODES.....	42
Figure 10-1 .....	42
10-108 - LIGHTNING PROTECTION SYSTEM DOWN CONDUCTORS AND GROUNDING ELECTRODES (SEE APPENDICES B & G).....	42



10-112 - MATERIAL FOR GROUNDING CONDUCTORS (SEE APPENDIX B) .....	42
10-116(1) - INSTALLATION OF GROUNDING CONDUCTORS.....	43
10-210 - GROUNDING CONNECTIONS FOR SOLIDLY GROUNDED AC SYSTEMS SUPPLIED BY THE SUPPLY AUTHORITY (SEE APPENDIX B) .....	43
Figure 10-2 .....	44
Figure 10-3 .....	44
Figure 10-4 .....	45
Figure 10-5 .....	46
Figure 10-5a .....	46
10-212(2) - GROUNDING CONNECTIONS FOR SOLIDLY GROUNDED SEPARATELY DERIVED SYSTEMS ..	47
10-302(2)&(3) - USE (SEE APPENDIX B) – IMPEDANCE GROUNDED SYSTEM .....	47
10-308 - CONDUCTORS USED WITH IMPEDANCE GROUNDING DEVICES (SEE APPENDIX B).....	47
10-400 - UNGROUNDED SYSTEMS.....	47
Figure 10-6 .....	48
10-604 - BONDING CONTINUITY FOR SERVICE EQUIPMENT .....	48
10-616 - SIZE OF SYSTEM BONDING JUMPER OR BONDING CONDUCTOR (SEE APPENDIX B) .....	48
Figure 10-7 .....	49
10-700 - EQUIPOTENTIAL BONDING OF NON-ELECTRICAL EQUIPMENT .....	49
(SEE APPENDIX B).....	49
SECTION 12 – WIRING METHODS .....	50
12-012 - UNDERGROUND INSTALLATIONS (SEE APPENDIX B).....	50
12-022 - CABLES OR RACEWAYS IN ROOF DECKING SYSTEMS (Q DECKING).....	51
Figure 12-1 .....	51
12-120 - SUPPORTING OF CABLES (SEE APPENDIX B).....	51
12-206 - OPEN WIRING RULES .....	51
12-406(4) - DLO AND FINE-STRAND CABLES PART 2 STANDARDS REQUIREMENTS.....	51
(SEE APPENDIX B).....	51
12-514 - PROTECTION OF CABLES IN NON-CONCEALED LOCATIONS.....	52
Figure 12-2 .....	52
12-608 – CONTINUITY OF ARMOURED CABLE (NOTE DELETED) .....	52
12-610 - TERMINATING ARMOURED CABLE (SEE APPENDIX B) (SEE ALSO 2-400).....	52
12-910(4) - CONDUCTORS AND CABLES IN CONDUIT AND TUBING.....	52
(SEE APPENDIX B).....	52
12-910 - TABLES .....	53



12-1118 - EXPANSION JOINTS (SEE APPENDIX B) .....	54
12-1404 - RESTRICTIONS ON USE - EMT .....	54
12-1414 - PROVISION FOR BONDING CONTINUITY - EMT .....	54
SECTION 14 – PROTECTION AND CONTROL.....	55
14-100(2) - LOADING CABLES (SEE APPENDIX B) .....	55
14-104(1) - ADJUSTABLE OVERCURRENT DEVICES (SEE APPENDIX B).....	55
14-114 - SUPPLEMENTARY PROTECTION (SEE APPENDIX B) .....	55
SECTION 16 – CLASS 1 AND CLASS 2 CIRCUITS .....	55
16-008 - HAZARDOUS LOCATIONS.....	55
SECTION 18 – HAZARDOUS LOCATIONS .....	55
18-002 - SPECIAL TERMINOLOGY (APPENDIX B).....	55
18-004 - CLASSIFICATION OF HAZARDOUS LOCATIONS .....	56
(SEE APPENDICES B, J, AND L) .....	56
Micro-breweries and alcohol distilleries.....	56
18-006 - AMMONIA COMPRESSOR ROOMS (SEE APPENDICES B AND L).....	56
18-008 - LOCATIONS CONTAINING AN EXPLOSIVE DUST ATMOSPHERE.....	56
(SEE APPENDICES B AND L) .....	56
Bio diesel and canola crushing plants .....	56
18-008 - HAZARDOUS AREA CLASSIFICATION - GRAIN ELEVATOR .....	57
Figure 18-1 .....	57
18-008 - HAZARDOUS AREA CLASSIFICATION - SEED CLEANING PLANT .....	58
Figure 18-2 .....	58
18-008 - HAZARDOUS AREA CLASSIFICATION - FEED MILL FLOOR PLAN.....	59
Figure 18-3 .....	59
Woodworking plants and sawmills .....	60
18-050 - ELECTRICAL EQUIPMENT (SEE APPENDICES B, AND J) .....	60
18-052 - MARKING OF EQUIPMENT.....	60
18-066 - INTRINSICALLY SAFE AND NON-INCENDIVE ELECTRICAL EQUIPMENT AND WIRING (SEE APPENDIX B).....	60
18-070 - COMBUSTIBLE GAS DETECTION (SEE APPENDICES B AND H).....	60
18-104, 18-154 - SEALING ZONE 1 & 2.....	61
18-152 & 18-252 - WIRING METHODS, ZONE 2 & ZONE 22 .....	62
18-250 - EQUIPMENT, ZONE 22 LOCATIONS .....	62
SECTION 20 – FLAMMABLE LIQUID AND GAS DISPENSING AND SERVICE STATIONS, GARAGES, BULK	



STORAGE PLANTS, FINISHING PROCESSES AND AIRCRAFT HANGARS.....	63
20-004 - ISLAND GAS PUMP.....	63
20-102(1) - HAZARDOUS AREA COMMERCIAL REPAIR GARAGES.....	64
20-102(2) & (3) - CLARIFICATION OF PITS OR DEPRESSIONS BELOW FLOOR LEVEL.....	64
20-200 - ANHYDROUS AMMONIA.....	64
20-300 - FINISHING PROCESSES.....	64
20-302 - PAINT MIXING ROOMS.....	64
SECTION 22 – LOCATIONS IN WHICH CORROSIVE LIQUIDS, VAPOURS OR EXCESSIVE MOISTURE ARE LIKELY TO BE PRESENT .....	65
22-002 - CATEGORIES (APPENDIX B).....	65
22-108 -WIRING DEVICES AND CONNECTORS .....	65
22-200(1) - WIRING METHODS IN CATEGORY 1 LOCATIONS.....	65
22-202 - WIRING METHODS IN CATEGORY 2 LOCATIONS .....	65
SEWAGE LIFT AND TREATMENT PLANTS .....	66
22-704 - CLASSIFICATION OF AREAS .....	66
22-804 - CLASSIFICATION OF AREAS.....	67
22-806 - ELECTRICAL EQUIPMENT, LUMINAIRES, AND RECEPTACLES.....	67
(SEE APPENDIX B).....	67
22-808 -WIRING METHODS (SEE APPENDIX B) .....	67
SECTION 24 – PATIENT CARE AREAS.....	68
DEFINITIONS - HEALTH CARE FACILITIES.....	68
24-000 - CLASSIFICATION OF AREAS .....	68
24-106(7) - RECEPTACLES IN BASIC CARE AREAS.....	69
24-110 - CIRCUITS IN INTERMEDIATE AND CRITICAL CARE AREAS.....	69
SECTION 26 – INSTALLATION OF ELECTRICAL EQUIPMENT.....	70
26-256 - LIMITING CURRENT OUTPUT (CHOKING) OF A DRY-TYPE TRANSFORMER .....	73
26-600 - LOCATION OF PANELBOARDS (SEE APPENDIX G).....	73
26-656 - BRANCH CIRCUITS FOR SINGLE DWELLINGS.....	73
26-658 - ARC FAULT PROTECTION OF BRANCH CIRCUITS FOR DWELLING UNITS.....	73
(SEE APPENDIX B).....	73
26-704 - PROTECTION OF RECEPTACLES BY A GROUND FAULT CIRCUIT.....	74
INTERRUPTER OF THE CLASS A TYPE (SEE APPENDIX B) .....	74
26-706 - TAMPER RESISTANT RECEPTACLES (SEE APPENDIX B) .....	74
26-710 - RECEPTACLES FOR MAINTENANCE OF EQUIPMENT ON ROOFTOPS.....	75



(SEE APPENDIX B).....	75
26-720 - GENERAL (SEE APPENDICES B & G) - RECEPTACLES INSTALLED IN CUPBOARDS .....	75
26-722 - RECEPTACLES FOR DWELLING UNITS (SEE ALSO 2-022) – KITCHEN RECEPTACLES .....	75
26-724 - RECEPTACLES FOR SINGLE DWELLINGS (SEE APPENDIX B) - GARAGE DOOR OPENERS .....	76
26-806 - HEATING EQUIPMENT RATED 117KW OR LESS (SEE APPENDIX B).....	76
26-956 - SUBMERSIBLE PUMPS INSTALLED IN BODIES OF WATER.....	77
SECTION 28 – MOTORS AND GENERATORS.....	78
28-104(1) - MOTOR SUPPLY CONDUCTOR INSULATION TEMPERATURE RATING AND AMPACITY (SEE APPENDIX B).....	78
28-110(1) - FEEDER CONDUCTORS .....	78
28-300 - OVERLOAD PROTECTION REQUIRED .....	78
28-604(1) - LOCATION OF DISCONNECTING MEANS .....	78
SECTION 30 – INSTALLATION OF LIGHTING EQUIPMENT .....	79
SECTION 32 – FIRE ALARMS AND FIRE PUMPS .....	79
SECTION 34 – SIGNS AND OUTLINE LIGHTING.....	79
34-000 - SCOPE - SIGNS AND OUTLINE LIGHTING.....	79
34-106 – LOCATION (LED DRIVER) .....	79
SECTION 36 – HIGH VOLTAGE INSTALLATIONS.....	80
36-004 - GUARDING .....	80
36-312 - GROUNDING OF METALLIC FENCE ENCLOSURES .....	80
SECTION 62 – FIXED ELECTRICAL SPACE AND SURFACE HEATING SYSTEMS .....	81
62-114 - OVERCURRENT PROTECTION AND GROUPING (SEE APPENDIX B).....	81
62-130 - HEATER CONTROLS INSTALLED IN PROXIMITY TO SINKS, TUBS, OR SHOWER STALLS.....	82
62-132 - HEATING DEVICES INSTALLED IN PROXIMITY TO SINKS, TUBS, OR SHOWER STALLS .....	82
62-200 - ELECTRIC SPACE HEATING (SEE APPENDIX B).....	82
SECTION 64 – RENEWABLE ENERGY SYSTEMS.....	83
64-002 - SPECIAL TERMINOLOGY.....	83
Figure 64-1 .....	83
64-058 - OVERCURRENT PROTECTION (ALL RENEWABLE ENERGY SYSTEMS).....	83





64-060 - DISCONNECTING MEANS (SEE ALSO 84-022, 84-024 & APPENDIX M).....	84
64-062 - WIRING METHODS.....	84
64-066 - UNGROUNDED RENEWABLE ENERGY POWER SYSTEMS.....	84
Figure 64-2 .....	85
Figure 64-3 .....	85
64-074 - Warning notices and diagrams (see Appendices B & M).....	85
64-110 - UNBALANCED INTERCONNECTIONS (INVERTERS).....	86
64-112 - UTILITY-INTERACTIVE POINT OF CONNECTION (INVERTERS).....	86
Figure 64-4 .....	86
Figure 64-5 .....	87
Figure 64-6 .....	87
Figure 64-7 .....	88
Figure 64-8 .....	88
64-202 - VOLTAGE OF SOLAR PHOTOVOLTAIC SYSTEMS.....	89
64-210 - WIRING METHODS.....	89
64-212 - INSULATED CONDUCTOR MARKING OR COLOUR CODING .....	90
64-214 - OVERCURRENT PROTECTION FOR APPARATUS AND CONDUCTORS.....	90
64-216 - PHOTOVOLTAIC DC ARC-FAULT PROTECTION .....	91
(SOLAR PHOTOVOLTAIC SYSTEMS) .....	91
64-218 - RAPID SHUTDOWN .....	91
64-802 - VENTILATION OF BATTERY ROOMS (SEE APPENDIX B) .....	91
64-804 - INSTALLATION (SEE APPENDIX B) .....	91
64-902 - MARKING .....	92
64-918 - LOCATION AND SEPARATION REQUIREMENTS FOR ENERGY STORAGE .....	92
SYSTEMS (SEE APPENDIX B) .....	92
SECTION 68 – POOLS, TUBS AND SPAS .....	93
68-000 - SCOPE .....	93
68-054 - UTILITY CONDUCTORS OVER POOLS .....	93
68-056 - UTILITY CONDUCTORS UNDER POOLS.....	93
68-308 - OTHER ELECTRICAL EQUIPMENT .....	93
SECTION 68 - POOL DIAGRAMS .....	94
SECTION 68 - POOL DIAGRAMS .....	95
SECTION 70 – TINY HOME REQUIREMENTS.....	97
SECTION 72 – MOBILE HOME AND RECREATIONAL VEHICLE PARKS.....	98



72-102(2) - DEMAND FACTORS FOR SERVICE AND FEEDERS.....	98
SECTION 76 – TEMPORARY WIRING .....	99
76-006 - SERVICE ENTRANCE EQUIPMENT .....	99
76-016 - RECEPTACLES .....	99
SECTION 78 – MARINE WHARVES, DOCKING FACILITIES, FIXED AND FLOATING PIERS AND BOATHOUSES .....	99
78-050 - RECEPTACLES .....	99
78-052 - BRANCH CIRCUITS AND FEEDERS .....	99
SECTION 84 – INTERCONNECTION OF ELECTRIC POWER PRODUCTION SOURCES .....	99
84-000 - PORTABLE GENERATORS .....	99
84-002 - GENERAL REQUIREMENT.....	100
84-020 - DISCONNECTING MEANS - ELECTRIC POWER PRODUCTION.....	100
84-022 - DISCONNECTING MEANS - SUPPLY AUTHORITY SYSTEM.....	100
84-024 - DISCONNECTING MEANS - GENERAL (SEE APPENDIX M).....	100
84-030 - WARNING NOTICE AND DIAGRAM (SEE APPENDIX M) .....	100
2-035 – OIL AND GAS FIELD INSTALLATIONS .....	101
MINING INSTALLATIONS .....	101
STANDARDS APPLICATIONS .....	101
APPROVED ELECTRICAL EQUIPMENT.....	101
2-012 - NOTIFICATION OF INSPECTION.....	101
2-014 - PLANS AND SPECIFICATIONS .....	101
12-402 - USE OF FLEXIBLE CORD .....	102
36-006 - WARNING NOTICE .....	102
M421-11 4.2.1.2 MINE PLANS.....	102
M421-11 4.3.3.4 IDENTIFICATION OF CABLES .....	102
M421-11 6.2.1 CONDUCTORS.....	102
APPENDIX E – DUST FREE ROOMS .....	103
E1 - INTRODUCTION.....	103
E2 - SCOPE.....	103
E3 - DEFINITION .....	103
E4 - USE .....	103
E4.1 .....	103
E4.2 .....	103
E5 - ENCLOSING OF ELECTRICAL EQUIPMENT .....	104



E5.1 .....	104
E5.2 .....	104
E5.3 .....	104
E6 - MATERIALS AND METHODS OF CONSTRUCTION.....	104
E7 - FLOORS.....	104
E8 - WALLS .....	105
E9 - CEILINGS.....	105
E10 - CUBICLE CONSTRUCTION.....	105
E10.1 .....	105
E10.2 .....	105
E11 - DOORS.....	105
E11.1 .....	105
E11.2 .....	106
E11.3 .....	106
E11.4 .....	106
E11.5 .....	106
E12 - WINDOWS.....	106
E12.1 .....	106
E12.2 .....	106
E13 - VENTILATION.....	106
E13.1 .....	106
E13.2 .....	106
E13.3 .....	106
E13.4 .....	106
E13.5 .....	107
APPENDIX M – RENEWABLES MARKING, WARNING NOTICES AND DIAGRAMS .....	108
64-060(10) - DISCONNECTING MEANS .....	108
64-066(1)(B) - UNGROUNDED RENEWABLE ENERGY POWER SYSTEMS.....	108
64-072(1) - MARKING.....	108
64-074(4) - WARNING NOTICE AND DIAGRAM.....	109
64-112(4)(B)(III) - INTERACTIVE POINT OF CONNECTION.....	109
64-200(1) - MARKING.....	109
64-200(2) - MARKING.....	110
64-202(5)(C) - VOLTAGE OF SOLAR PHOTOVOLTAIC SYSTEMS.....	110



64-218(5) - PHOTOVOLTAIC RAPID SHUTDOWN .....	110
64-218(6) - PHOTOVOLTAIC RAPID SHUTDOWN .....	111
84-030(1) - WARNING NOTICE AND DIAGRAM.....	111
84-030(2) - WARNING NOTICE AND DIAGRAM.....	112
PORTABLE ELECTRIC POWER PLANTS (AS PER OH&S REGULATIONS 1996) .....	113
Appendix of Amendments: .....	116



## △ WEBSITE INFORMATION

**Publications Saskatchewan:** <https://publications.saskatchewan.ca/#/freelaw/acts>

- Electrical Inspection Act, 1993: E-6.3
- Electrical Inspection Regulations: E-6.3 R1, E-6.3 R16
- Electrical Licensing Act: E-7.2
- Electrical Licensing Regulations: E-7.2 R4

**TSASK:** [www.tsask.ca](http://www.tsask.ca)

- 2021 CEC Saskatchewan Interpretations and Information
- Approved Field Inspection Agencies and Certification Bodies
- District Inspector Contact Numbers
- District Inspector Territory Maps
- Electrical Fee Schedule
- Code for Electrical Installations at Oil & Gas Facilities
- Wind & Solar Information
- [Link to Electrical Inspection Act and Electrical Inspection Regulations](#)

**SaskPower:** [www.saskpower.com](http://www.saskpower.com)

- SaskPower Electric Service Requirements
- SaskPower New Connect Process

## BOND NOTICE ADMINISTRATION FEES

When defects are due, a bond notice will be issued and an administration fee as per the electric fee schedule will be incurred. The invoice will be issued to the contractor at the same time the bond notice is issued to the applicable bond company for completion of said defect.

## UNREPORTED WORK PENALTY – ELECTRICAL INSPECTION REGULATION

The Electrical Inspection Regulations have allowed a change to the unreported work penalty, see the latest Electrical Fee Schedule for details.

## ENERGIZATION STICKERS

As a reminder, energization stickers shall not be applied to any meter socket unless a **paid Electrical Permit has been obtained for the service.**

Failure to comply with the specific requirements listed for the application of energization stickers by the Electrical Contractor will result in fines and penalties being assessed against the contractor.

## ELECTRICAL INSPECTIONS REGISTERED ELECTRICAL CONTRACTOR PROGRAM

Electrical contractors may be eligible for a 10% discount for customer electrical permits.

To improve and maintain safety and consistency of electrical installations, Electrical Inspections has introduced the Registered Electrical Contractor Program to electrical contractors who meet the following criteria on an annual basis:

- a) Participate in a continuing education program under the umbrella of the Electrical Contractors Association of Saskatchewan (ECAS);
- b) Maintain a defect ratio of four percent or below on all inspected permits and have a minimum of 20 inspected permits per year;
- c) Have no incidents of unreported work and disclose all information related to the electrical installation/permit;
- d) Take out online permits only; and
- e) Correct any defects within the date of expiry and have no incidents of bond action (an incident of bond action will result in the immediate loss of status).

### How does it work?

- a) Beginning January 1, 2018, contractors will have their history tracked to verify that all requirements have been met;
- b) Successful contractors will be notified in February that they have achieved registered contractor status;
- c) Once a contractor has reached registered status, the 10% rebate is applied to all permits starting the following February; and
- d) Contractors will be required to meet the standards annually to remain a registered contractor and will continue to have their history tracked.

**NOTE:** Use of the TSASK Logo for this purpose is strictly prohibited.

### Inquiries

Contact Electrical Inspection Supervisors for more information.

## JOURNEYMAN LICENCE (SEE THE ELECTRICAL LICENSING ACT E-7.2)

8(1) Subject to Subsection (2), no person shall do any work of electrical installation unless he holds a licence.

## EMPLOYER'S LICENCE (SEE THE ELECTRICAL LICENSING ACT E-7.2)

23(1) No employer shall do any work of electrical installation unless he holds an employer's licence.



(2) An employer's licence may be issued to a person who employs at least one individual who holds a journeyman's licence; and is not employed by a holder of a licence other than the applicant unless the other holder holds a supply house licence;

(3) No employer shall require or permit any apprentice or other unlicensed individual to perform any work of electrical installation except as an assistant to, and under the supervision of, a journeyman.



## SECTION 2 – GENERAL RULES

### 2-004 - PERMIT

#### Permit information

It is the responsibility of the contractor to ensure that the information given on the permit application is accurate and complete. Inaccurate details may result in delayed service connects:

- △ 1. Ensure the address where the work being performed is accurate and complete. Additional information is required where no civic address is available i.e., beaches, new subdivisions, oilfield lease sites, reserves, etc.
- △ 2. Supply work/cell contact phone number and name for the owner. Failure to provide accurate and legible information on any permit application could result in the following:
  - a. An inspection fee may be charged to locate missing or inaccurate information; or
  - b. The application and payment may be returned to the contractor to update missing or inaccurate information. A fine (as per the Electrical Fee Schedule) for unreported work as per *The Electrical Inspection Regulations* may be assessed for any work that is not authorized by a valid permit.

Section 16 of *The Electrical Inspection Act, 1993* and Section 7 of *The Electrical Inspection Regulations* specifies that all permit applications must be accompanied by the appropriate fee.

#### △ Commencement of Work (note deleted)

#### Permit expiry date

- △ Permits shall expire one year after the issuance of a permit. Permits shall continue to be valid beyond one year by special permission. *Supplemental permits* must be submitted within 3 years of the permit issue date. After that time, a new permit must be obtained.

## △ 2-004 - Permits for low voltage and extra low voltage installations

All low voltage and extra low voltage installations including lighting, home automation control wiring, power over ethernet (POE), process controls, fire alarm systems, heating/cooling control wiring, control/communication cable tray and conduit systems, solar powered systems, cathodic protection and SCADA systems require permits. The Electrical Inspection Regulations (available at Publications Saskatchewan <https://publications.saskatchewan.ca/#/freelaw/acts>) have been amended to exempt the requirement of an electrical permit for the installation of communication cabling.

### E-6.3 REG 1 - 6.1(1) In this Section:

- a) “code” means the latest prescribed edition of the CEC within the meaning of subsection 5(2) of the Act;
- b) “communication system” means a communication system as defined in Section 0 of the code;
- c) “control circuit” means a control circuit as defined in Section 0 of the code;
- d) “hazardous location” means a location to which Section 18 of the code applies;
- e) “patient care area” means an area to which Section 24 of the code applies.

### E-6.3 REG 1 - 6.1(2)

Subsection 16(2) of the Act does not apply to the following types of work of electrical installation:

- a) the replacement of switches, receptacles, ballasts, lighting fixtures or motors, in single-family dwelling units and in non-detached dwelling units with separate entrances that are intended for the use of one family; and
- b) the installation of a communication system, other than a communication system:
  - i. that is located in a hazardous location;
  - ii. that is located in a patient care area; or
  - iii. in which control circuits operate the electrical equipment i.e., home automation or SCADA systems.

### Notes:

- 1) This exemption also applies to security systems, except that permits will still be required under the following conditions:
  - security systems installed in hazardous locations;
  - security systems installed in patient care areas; or
  - security systems that have a hard-wired 120-volt supply (not a plug-in device).
- 2) 6.1(1) d) “hazardous location” described in Reg. 1 shall also include a location to which Sections, 19 (Oil & Gas Code) 20 and 22 of the code apply.
  - Non-hazardous work in a non-hazardous environment on an oil field site, does not require the permit selection to be hazardous.
- 3) The installation of the associated equipment, conduit system, etc. still requires a permit.
- 4) 6.1(2) Subrule a) is for replacement only without altering the existing wiring installation.



## 2-004 - PERMITS FOR SIGNS AND OUTLINE LIGHTING

- △ Permits are required for the connection of all signs and outline lighting. The permit fee shall include the wiring to the sign and be as per the Electrical Fee Schedule. See also [Section 34](#).

## 2-004 - PERMITS FOR CUSTOMER SUPPLIED EQUIPMENT AND SKIDS

- △ Permits are required for the connection of all customer supplied equipment and skids. The permit fee shall include the wiring to the equipment and the cost of the equipment and skids as per the Electrical Fee Schedule.

## 2-012 - INSPECTION REQUEST REQUIRED

For scheduling purposes, a two-week notice is required for an inspection of, but not limited to, the following installations prior to concealment, operation and/or utility connection, and the contractor may be requested to be present for:

- a) Main service over 400 amps;
- b) Feeders over 400 amps;
- c) Medical facilities that contain patient care areas, prior to closing in of walls;
- d) High voltage installations, including grounding;
- e) Energy production such as solar and wind, generation, battery storage systems;
- f) Buildings housing livestock or poultry;
- g) High voltage neon signs and outline lighting;
- h) Sewage lift and sewage/water treatment facilities;
- i) Irrigation systems;
- △ j) Marinas; and
- k) Other areas and facilities with restricted access.

### NOTE:

- △
- To facilitate the inspection of the installations, contractor photos can be attached to the permit in the Permit System or available at the time of the inspection to show the wiring installation, grounding connection and bonding of the equipment and installation of the equipment.

## 2-014 - PLANS AND SPECIFICATIONS

- 1) One set of construction electrical plans and specifications, as required by Section 19 of *The Electrical Inspection Act, 1993* or as requested by the Electrical Inspections department, shall be submitted to and reviewed by the Electrical Inspections department for:
  - a) Main service and or feeders where ampacity is over 400A;
  - b) All renewable energy systems installations;
  - c) Sewage lift and treatment facilities;

- d) Class A, B and C health care facilities as indicated by the current edition of the Z32 Standard, including identification of the patient care areas (See [Section 24](#) in the Saskatchewan Interpretations for definitions);
  - △ e) Installations covered by Sections 18, 19 (Oil & Gas Code - excluding single oil well sites < 1000V) 20 and 22 (Note – Reclassification of areas must be performed by a Professional Engineer complete with an assessment report and stamped drawings);
  - f) High voltage services and feeders;
  - g) Irrigation systems;
  - △ h) Marinas, wharves, docking facilities, fixed/floating piers and boathouses;
  - i) Generator systems over 12 KW; or
  - j) Any other installation as deemed necessary by the Electrical Inspections department (e.g., large renovations of public buildings).
- 2) Submissions shall include the following information:
- a) Submitter (consultant/contractor/client) contact information:
    - Company name
    - Mailing address
    - Phone number
    - Email address
  - b) Project name, construction site address and/or land location.
  - c) Clearly specify the scope of the work.
  - d) Clearly identify existing, new, and future part of the project.
  - e) Electrical plans shall include the following:
    - 1) Detailed site plan;
    - 2) An overall single line diagram complete with:
      - Main service ampacity, voltage and phase;
      - Main and feeder conductor type and sizes including installation method i.e., underground (as per the D Tables and Diagrams), conduit, free air, bundled or raceway;
      - Panel schedules indicating current and voltage ratings;
      - Breaker/fuse size;
      - Conductor material (copper or aluminum);
      - Maximum short circuit current available at main service;
      - Transformer ratings, primary and secondary overcurrent protection devices and conductor sizes; and
      - Grounding and bonding details;
    - 3) Hazardous area classification drawings, which shall include the auto ignition temperature (AIT) of the hazardous product present at the site;
    - 4) Patient care areas (clearly identify the different patient care levels);
    - 5) Calculated loads;
    - 6) Cable schedule;
    - 7) Cablebus;

- 8) Electrical equipment layout; and
  - 9) Voltage drop calculation for services and feeders.
- △ f) For high voltage (over 1000V) installations, in addition to the applicable items in (e), the following information shall be submitted:
- 1) Electrical equipment arrangement complete with elevation, profile views and physical arrangement of the electrical equipment dimensions to clearly indicate the electrical, physical and work clearances and relative locations of the equipment;
  - 2) Ground potential rise (GPR) study;
  - 3) Fencing arrangement and details (see [36-312](#));
  - 4) Grounding and bonding details (including impedance grounding wiring details);
  - 5) Provisions for metering equipment; and
  - 6) Other design information and documents as requested by Electrical Inspections.
- g) Plans submission for a renewable energy system shall include, but not be limited to:
- 1) [Renewable Energy Information Check Sheet](#) must be submitted with all renewable energy installation plans: visit [www.tsask.ca](http://www.tsask.ca) for the [check sheet](#);
  - 2) manufacturers specification or data sheets for racking systems, PV modules, DC combiners, inverters, rapid shutdown, etc.;
  - 3) a detailed site plan showing the relative locations of all electrical equipment including the length of all feeders and any applicable voltage drop calculations; and
  - 4) an overall single line diagram shall contain the following:
    - All electrical equipment (new and existing) and where this equipment connects to any electrical systems on the property such as PV array, DC combiner, inverter, disconnect, breaker/fuse, panel, etc.
    - Show all specific wiring and installation methods for the entire electrical installation (i.e., copper or aluminum conductors, PVC conduit, EMT, ACWU or TECK cables, underground, indoor/outdoor location, etc.)
    - All grounding and bonding details of any new electrical equipment.
    - The interactive point of connection as applicable in Rule 64-112 shall be shown. For example, if the connection is on the load side of the service disconnecting means such as a panelboard, splitter or other distribution equipment, provide bus amperage rating, utility source breaker and the renewable energy system input breaker ratings.
  - 5) solar array details required are:
    - The maximum photovoltaic source circuit voltage as calculated by Rule 64-202 (N/A for micro-inverters, optimizers);
    - The rated short-circuit current (N/A for micro-inverters);
    - The rated operating current and voltage;
    - The type and number of PV modules connected in each series string;
    - The specific wiring methods for the solar array as applicable in CEC Rules [64-210](#), [64-212](#), & [64-220](#); and
    - For rapid shutdown initiation devices, show the location of equipment placards as per the local fire department (see Appendix M).

h) Plans submission for irrigation systems shall include, but not be limited to:

- Services;
- Pump electrical data;
- Pump controllers;
- Cable sizes and distances;
- Approval from AHJ for use in navigable waters;
- Buoy requirements; and
- Application for Deviation



i) Plans submission for marinas, wharves, docking facilities, fixed/floating piers and boathouses shall include, but not be limited to:

- Service size;
- Demand calculation;
- Single Line Drawing (including conductor size, type & distance, ground fault, and grounding & bonding details);
- Electrical equipment specifications;



3) Submit plans via the [Electrical Plans Portal by clicking here](#)

4) Plans review fees will be as per most recent version of TSASK Electrical Fee Schedule.

**NOTES:**



1. The electrical contractor shall ensure that the plans have been submitted to Electrical Inspections.
2. The electrical contractor shall ensure that any main service and/or feeder conductor/cable changes made during construction, be submitted on an updated SLD to Electrical Inspections for addition to the GEIS database for review by the Local Inspector.
3. The electrical contractor shall ensure that any substantial changes made during construction be re-submitted to Electrical Inspections for review.
4. Each electrical contractor, for a complex industrial installation, shall ensure that plans are submitted covering the portion of the installation they are responsible for including the permit number and project designation/name/number, etc.
5. Where plans have not been submitted and reviewed by Electrical Inspections, service energization may be denied.





6. Plans are entered in the queue and reviewed in the order they are received. Submissions missing any required information will be moved back into the queue.
7. Construction set of electrical plans should be submitted prior to construction or at least 6 weeks prior to the required pre-inspection and the service energization. The standard turnaround time for the review process is approximately four to six (4 to 6) weeks. For high voltage submissions, the review process is approximately six to eight (6 to 8) weeks. The review process timeline may be longer depending on the number of submissions received.
8. Upon completion of review, the Plans Review letter will be issued to the submitter.
9. NOTE – A copy of the Plans Review letter should be made available at the time of the inspection.
10. Contractor/designer/engineer shall ensure that the customer has a utility interconnection agreement with the utility.
11. Contractor/designer/engineer shall ensure that the customer has a utility letter of acceptance for the installation of closed transition transfer switches as per Rule [84-002](#).
12. Where an emergency power supply is installed to supply power to life safety systems as defined in Rule 46-002, a selective coordination report will be required to be submitted to Electrical Inspections as per 46-208.

## 2-022 - RENOVATIONS OF EXISTING INSTALLATIONS

### Connection or reconnection (see [10-102](#))

-  A permit is required for reconnection of a service disconnected due to fire or flood to ensure it is being energized in a safe state.
-  A permit is required, and the service shall be made to comply with the requirements of the current edition of the Canadian Electrical Code where the service:
  - has been disconnected for more than twelve (12) months;
  - has been damaged due to a fire or flood; or
  - requires reconnection due to an upgrade, alteration, or repair (e.g., main breaker failure).

### NOTES:

-  • Installation of a meter mounted transfer switch device shall require verification of the service grounding and bonding.
-  • Wooden masts will not be accepted when a permit is required for a service alteration or upgrade.
-  • When a service is being altered or upgraded, round meter bases shall be replaced due to the inability to effectively terminate and ground the neutral.
- A pre-inspection and plans may also be required in accordance with [2-012](#) and [2-014](#).

- All meter sockets shall be securely mounted which may require a fixed wood backing minimum 19mm (3/4") thickness, at least the same width as the meter socket, and pressure treated or clad for protection.
- △
- When replacing a service, it is the contractor's responsibility to ensure branch circuit integrity (i.e., GFCI protection ahead of altered 2-wire circuits, circuit insulation, etc.).

### Flood Procedures

- △ When restoring power to a flood damaged premise, there are several conditions to be aware of and processes to comply with. All work must meet the requirements of the current CEC. When electrical equipment is exposed to water, corrosion is enhanced rapidly. The equipment may look safe on the outside, but it can be extremely dangerous to reuse. **The Local Electrical Inspector must be notified before reconnection.**

1. Circuits and equipment that were subjected to the flood must be disconnected and isolated before power can be restored.
2. If the service (panelboard, etc.) has been exposed to water, it must be replaced or completely disassembled and cleaned (re-approval by manufacturer required after reassembly). All the submerged or deluged breakers must be replaced and destroyed. When service equipment is replaced, the entire service must be brought up to the current CEC.
3. All meter sockets must be securely mounted.
4. Grounding must be checked and if repairs are required, they must meet the requirements of the current CEC. Ground clamps should be cleaned or replaced.
5. All submerged or deluged conductors, cable, equipment, receptacles, switches, etc. must be replaced and the damaged material destroyed.
6. Conduit systems that have been flooded shall be cleaned and a bond wire shall be installed with the new conductors.
7. Furnaces and water heaters must be checked over by a qualified gas contractor.

### Electrical systems exposed to fire

When a building has had a fire and the panelboard and equipment have been exposed to smoke and/or water.

1. If the panelboard has not been damaged by heat etc. it may be thoroughly cleaned and reused (re-certification required or a letter of acceptance from manufacturer after reassembly).
2. All breakers, receptacles, switches, lighting, and heating fixtures that have been exposed to the smoke and/or water must be replaced, and the old ones destroyed.
3. Any wiring that may have been exposed to flames or heat in excess of its maximum temperature rating must be replaced.
4. All repair/replacement work must meet the requirements of the current CEC.

## Renovating of existing installations

Where during a renovation or repair work, the walls are opened or if cabinetry is removed/replaced, then every effort shall be made to ensure that the electrical wiring and circuitry for all outlets is brought up to the current CEC. Electrical Inspections may be consulted for clarification on what is required specifically to satisfy this policy.



When adding loads such as: air conditioners, hot tubs, EV chargers, etc. it will be the contractor's responsibility to ensure load calculations have been performed as the Local Electrical Inspector may require supporting documentation.

## 2-024 - USE OF APPROVED EQUIPMENT (SEE ALSO FIELD INSPECTION AGENCIES AND CERTIFICATION BODIES BOOKLET)

All electrical equipment shall be approved as per Rule [2-024](#) and Appendix B note with the exception as per Rule 16-222.

*Labels are required for manufactured homes and movable equipment wired under a Saskatchewan electrical permit.*

Skids and movable equipment that have been wired off site shall have a suitable, weatherproof if required, label affixed to the electrical panel or skid. The label shall include the Saskatchewan electrical contractor's name, the permit number that was issued for the installation and the date.

Manufactured homes [ready to move homes (RTM)] shall have a label affixed to the electrical panelboard or the inside of the kitchen cabinet. The label shall include the Saskatchewan electrical contractor's name, the permit number that was issued for the installation and the date. If you require labels, please contact your *Local Electrical Inspector*.

### Equipment approval certification

All electrical equipment requires an overall approval from a Saskatchewan recognized certification body prior to being sold, advertised, electrically connected or reconnected. This includes locally manufactured products, used or rebuilt equipment, solar powered generating units used for temporary construction power or lighting, and may also include mobile homes, and RTM's. For a complete list of approved certification bodies and certification marks, please visit the TSASK website at [www.tsask.ca](http://www.tsask.ca).

### Field inspection certification

For a list of current recognized field certification labels for the Province of Saskatchewan, contact Electrical Inspections at our toll-free number 1-866-530-8599, or visit us online at [www.tsask.ca](http://www.tsask.ca).

### Field inspection / Field evaluation reports

Field inspection reports on skids or moveable equipment shall become part of the equipment and shall be made available on request. Report shall remain with the equipment.



## 2-024 - USE OF APPROVED EQUIPMENT - EXCEPTIONS

There may be occasions where certification standards do not exist for approval of electrical equipment. A deviation shall be applied for in accordance with Rule [2-030](#).

### LIQUID-FILLED TRANSFORMERS

In the specific situation of liquid-filled transformers, certification organizations have yet to identify a demand for developing a product certification program around this electrical equipment. Consequently, certified liquid-filled transformers are not available.

#### Conditions

Owners/users required to use liquid-filled transformers are permitted to deviate from Rule 2-024 of the CEC provided they meet the following conditions:

#### 1. Manufacturing standards

##### a) Manufactured to Canadian standards

Liquid-filled transformers are acceptable when the manufacturer declares that they have manufactured, inspected, and tested the transformer to the requirements of the appropriate and current Canadian standards. These standards include, but not limited, to:

- CAN/CSA-C2.1 Single Phase and Three Phase Distribution Transformers
- CAN/CSA-C88-16 Power Transformers and Reactors
- CAN/CSA-C227.3-06(R17) Low Profile, Single Phase, Dead Front Pad-mounted, Distribution Transformers
- CAN/CSA-C227.4-06(R17) Three Phase, Dead Front Pad-mounted, Distribution Transformers

##### b) Manufactured to other than Canadian standards

- Where liquid-filled transformers are manufactured to other than Canadian standards, the manufacturer must declare that the product has equivalent safety performance as one manufactured to Canadian standards. Alternatively, a Professional Engineer may evaluate and accept the product standard to which the liquid-filled transformer was manufactured if it compares favorably with the appropriate Canadian standards concerning safety performance.

#### 2. Product identification

In addition to meeting the requirements of Rule 2-100 of the CEC, the liquid-filled transformer must identify the standard to which it was manufactured. The following documentation of appropriate marking must also accompany the product:

- a) a manufacturer's declaration stating that they have manufactured the product to one or more appropriate Canadian standards; or
- b) when manufactured to other than Canadian standards:



- i) a manufacturer's declaration that the product has equivalent safety performance as one manufactured to the appropriate Canadian standards; or
  - ii) a Professional Engineer's evaluation report indicating the product as having equivalent safety performance as one manufactured to appropriate Canadian standards.
3. Maintenance
- The owner of the equipment shall ensure the product is maintained to industry standards and manufacturer's specifications.

## HV DOWNHOLE ESP'S (ELECTRICAL SUBMERSIBLE PUMPS)

Manufacturers, distributors, owners, and installers of ESPs and associated down-hole cables shall be permitted to deviate from Rule 2-024 of the Canadian Electrical Code provided they meet the following conditions:

### Conditions

1. Manufacturing standards
    - a) Manufactured to North American Standards:

ESP's and/or associated down hole cables are acceptable when the manufacturer declares that they have manufactured, inspected, and tested the ESP's and/or associated down-hole cables to the requirements of the appropriate and current standards. These standards include but are not limited to:

      - IEEE 252 Standard Test Procedure for Polyphase Induction Motors having Liquid in the Magnetic Gap.
      - IEEE 1017 Recommended Practice for Field Testing Electric Submersible Pump Cable.
      - IEEE 1018 Recommended Practice for specifying Electric Submersible Pump Cable Ethylene-Propylene Rubber Insulation.
      - IEEE 1019 Recommended Practice for specifying Electric Submersible Pump Cable Polypropylene Rubber Insulation.
      - Manufactured to Other than North American Standards:

Where ESPs and/or associated down-hole cables are manufactured to other than North American standards, the manufacturer must declare that the product has equivalent safety performance as one manufactured to North American standards. Alternatively, a licensed engineering professional may evaluate and accept the product standard to which the ESP's and/or associated down-hole cables were manufactured to, if it compares favourably with the appropriate North American standards concerning safety performance.
  2. Product Identification
- The following documentation for ESPs and associated down-hole cables must be readily accessible:

- A manufacturer's declaration stating that the product meets industry recognized standards; and
  - Specification sheets stating the product's electrical ratings and characteristics.
3. Additional Requirements
- The installation is bonded to ground in accordance with Section 10;
  - Proper overcurrent and overload protection must be provided in accordance with the CEC, Part 1; and
  - All above ground components associated with the installations meet the requirements of the CEC Part 1.

## 2-030 - DEVIATION OR POSTPONEMENT

Requests for special permission shall be made in writing to the Chief Electrical Inspector, giving all details pertaining to the requests. If acceptable, permission applying to that installation only will be confirmed in writing.

## 2-106 - REBUILT EQUIPMENT

### Retrofit kits and installation requirements

With the application of energy efficiency programs in Saskatchewan, high efficiency lighting technologies and various lighting retrofit kits are popular. There are several options for retrofitting standard tubular fluorescent luminaires, with more energy efficient lamps.

The retrofit of luminaires and signs may be accepted under the original certification when the following conditions apply:

- The work is covered by an electrical permit;
- The replacement equipment bears the mark of a recognized certification agency; or
- The replacement equipment is rated for the application and draws no more power than the original equipment.

Please note that in all cases, each retrofitted luminaire or sign must be provided with a label containing the following information:

- Voltage;
- Amperage;
- Date of install;
- Installed by (contractor name);
- Permit number, and
- Over 150 V to ground on the socket for double ended lamps, a label shall be installed stating, **Caution - De-energize prior to changing tubes.**

Some retrofit options are:

- Fluorescent retrofit kit – consists of fluorescent tube and electronic ballast that is an integral part of the device.

- LED retrofit kit – consists of an LED retrofit tube and the LED driver components that are remote from (not an integral part of) the device.
- LED retrofit kit with integral driver – consists of an LED tube and the LED driver components that are an integral part of the device.

Retrofit kits specified above require a luminaire conversion and usually involve replacing the lamp, rewiring the luminaire and in some cases, replacing an existing ballast with an LED driver, or directly connecting the lamp to the supply circuit.

Although there are differences in installation of various retrofit kits, for all of them it is very important to consider that the retrofit kits are certified as assemblies to appropriate Canadian standard(s).

### **Hazardous location luminaires**

Hazardous location luminaire certifications investigate all components to ensure they are not or will not become an ignition source. Electrical Inspections requires that hazardous location luminaire retrofit kits be certified to the appropriate standard.

Field modifications to hazardous location luminaires including internal wiring re-work bypassing existing ballast and wiring directly to the socket with phase voltage, shall be field certified by an approved certification body.

## **2-200 - PROTECTION OF EQUIPMENT**

### **8-400 Commercial automobile receptacles & 8-500 Electric Vehicle charging stations**

To prevent damage by vehicles, receptacles shall be protected by one of the following or other equivalent means:

- a. approved manufactured flexible impact resistant pedestals;
- b. where mechanical protection is not utilized, the receptacles and conduit shall be installed on structures of adequate strength, such as fences, or walls and the receptacles and conduit shall be installed no less than 750 mm (30") above finished grade;
- c. a reinforced concrete post with a dimension of not less than 300 mm (12") may be used and shall be installed to a height of not less than 750 mm (30") and to a depth of not less than 750 mm (30") below grade. The receptacles and conduit shall be installed on the face of the post not exposed to vehicular damage. The receptacles may, if desired, be installed on the face of the post exposed to vehicles provided the conduit and outlet box are installed within the post. Mounting height of the receptacles shall not be less than 750 mm (30") above finished grade. As an alternate to the concrete post, a treated wooden post of minimum 150 mm x 150 mm (6x6) may be used; or
- d. bollards or permanently installed curb stops, mounted 1.2 m (4') from the center of the curb stop to the pedestal or receptacle, for drive in parking locations and placed in front of the receptacles to prevent vehicles from damaging receptacle pedestals, shall be accepted as mechanical protection.

Conductors for wiring of these receptacles shall have insulation or covering suitable for installation and use at temperatures down to -40 OC except for conductors approved for and installed underground.

A separate bonding conductor is required in metal raceway as per Rule 10-606 & [12-1414](#).

## 2-300 - GENERAL REQUIREMENTS FOR MAINTENANCE AND OPERATION

Currently there is a concern with free standing services falling over from a lack of support and services not being adequately protected against weather. Free standing services shall meet the following minimum requirements with all posts set to a minimum depth of 750 mm (30") and additional support to deal with any cantilever forces placed upon the structure.

- a) 100 A – 200 A services shall be supported on a minimum of 2 pressure treated 100 mm x 100 mm (4x4) posts with a 21 mm (¾") pressure treated backing.
- b) 300 A – 800 A services shall be supported on a minimum of 3 pressure treated 150 mm x 150 mm (6x6) posts with a 21 mm (¾") pressure treated backing.
- c) 1000 A and larger - same as (b) and shall have additional support as required.

**Outdoor services shall require substantial weather resistant construction.**

## 2-328 - ELECTRICAL EQUIPMENT NEAR COMBUSTIBLE GAS EQUIPMENT

The clearance around a natural gas regulator relief vent to arc-producing electrical equipment shall be 1 meter (39") and 3 meters (10') for propane regulator relief vents as per CSA B149.1-15.

### NOTES:



- This clearance is a spherical radius.
- Revenue meters, hot tub and air-conditioning disconnects are examples of arc-producing electrical equipment.

## 2-400 - ENCLOSURES, TYPE, DESIGNATION, AND USE (SEE APPENDIX B) (SEE ALSO 12-610)



When entering equipment being used outdoors, weatherproof connectors shall be the only acceptable method of entry to ensure the integrity of the installation.



## SECTION 4 – CONDUCTORS

### D8 TABLES WITH 75° CALCULATIONS

**Table D8A**  
**Allowable copper conductor ampacities for cables rated not more than 5000 V and unshielded for the installation configurations of Diagram D8**

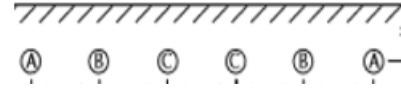

(see Rule 4-004.)

Size,AWG or Kcmil	1/phase, Detail 1		2/phase, Detail 2		2/phase, Detail 3		4/phase, Detail 4		4/phase, Detail 5		6/phase, Detail 6		6/phase, Detail 7	
	90 °C	75 °C	90 °C	75 °C	90 °C	75 °C	90 °C	75 °C	90 °C	75 °C	90 °C	75 °C	90 °C	75 °C
1 / 0	315	279	269	238	288	255	204	181	221	196	171	152	186	165
2 / 0	357	316	304	269	326	289	230	204	249	221	192	170	209	185
3 / 0	405	359	343	304	369	327	259	229	281	249	217	192	236	209
4 / 0	458	406	388	344	418	370	292	259	317	281	244	216	265	235
250	499	442	422	374	454	402	317	281	344	305	265	235	289	256
300	550	487	464	411	500	443	348	308	378	335	291	258	317	281
350	597	529	503	446	543	481	376	333	409	362	314	278	342	303
400	642	569	540	478	582	516	403	357	439	389	336	298	366	324
500	721	639	605	536	654	579	451	400	491	435	375	332	409	362
600	790	700	662	587	716	634	493	437	536	475	410	363	447	396
750	885	784	740	656	801	710	549	486	598	530	457	405	498	441
900	972	861	810	718	877	777	599	531	653	579	498	441	543	481
1000	1020	904	850	753	921	816	629	557	686	608	522	462	570	505
1250	1132	1003	941	834	1020	904	694	615	757	671	576	510	629	557
1500	1227	1087	1017	901	1104	978	749	664	817	724	621	550	678	601
1750	1308	1159	1083	960	1176	1042	796	705	869	770	659	584	720	638
2000	1376	1219	1138	1008	1236	1095	835	740	911	807	691	612	755	669

**Notes:**

- (1) This table gives the allowable current for 90 °C rated single copper conductors with spacings directly buried in earth.
- (2) Underground ampacities for a conductor temperature of 75 °C may be obtained by multiplying the appropriate ampacity at 90 °C conductor temperature by the derating factor 0.886.
- (3) See Rule 4-006 for equipment termination temperature requirements.

**Table D8B**  
**Allowable aluminum conductor ampacities for cables rated not more than 5000 V and unshielded for the installation configurations of Diagram D8**

(see Rule 4-004.)

Size,AWG or Kcmil	1/phase, Detail 1		2/phase, Detail 2		2/phase, Detail 3		4/phase, Detail 4		4/phase, Detail 5		6/phase, Detail 6		6/phase, Detail 7	
	90 °C	75 °C	90 °C	75 °C	90 °C	75 °C	90 °C	75 °C	90 °C	75 °C	90 °C	75 °C	90 °C	75 °C
1 / 0	244	216	208	184	223	198	158	140	172	152	133	118	144	128
2 / 0	276	245	236	209	253	224	179	159	194	172	150	133	163	144
3 / 0	313	277	266	236	286	253	201	178	218	193	169	150	183	162
4 / 0	356	315	302	268	325	288	227	201	247	219	190	168	207	183
250	387	343	328	291	353	313	247	219	268	237	206	183	225	199
300	427	378	361	320	389	345	271	240	294	260	226	200	247	219
350	464	411	391	346	422	374	293	260	319	283	245	217	267	237
400	498	441	420	372	453	401	314	278	342	303	262	232	286	253
500	561	497	472	418	509	451	352	312	383	339	293	260	320	284
600	617	547	518	459	559	495	386	342	420	372	321	284	350	310
750	694	615	581	515	628	556	432	383	470	416	359	318	392	347
900	764	677	638	565	691	612	473	419	515	456	393	348	429	380
1000	807	715	673	596	729	646	498	441	543	481	414	367	452	400
1250	906	803	753	667	817	724	556	493	606	537	461	408	503	446
1500	992	879	822	728	893	791	605	536	661	586	502	445	548	486
1750	1068	946	884	783	960	851	649	575	709	628	538	477	588	521
2000	1134	1005	937	830	1018	902	687	609	751	665	569	504	622	551

**Notes:**

- (1) This table gives the allowable current for 90 °C rated single aluminum conductors with spacings directly buried in earth.
- (2) Underground ampacities for a conductor temperature of 75 °C may be obtained by multiplying the appropriate ampacity at 90 °C conductor temperature by the derating factor 0.886.
- (3) See Rule 4-006 for equipment termination temperature requirements.



## D9 TABLES WITH 75° CALCULATIONS

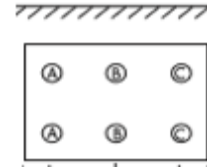

**Table D9A**  
**Allowable copper conductor ampacities for cables**  
**rated not more than 5000 V and unshielded for the**  
**installation configurations of Diagram D9**

(see Rule 4-004.)

Size, AWG or Kcmil	1/phase, Detail 1		2/phase, Detail 2		4/phase, Detail 3		6/phase, Detail 4	
	90 °C	75 °C	90 °C	75 °C	90 °C	75 °C	90 °C	75 °C
1/0	258	229	221	196	181	160	165	146
2/0	293	260	250	222	205	182	186	165
3/0	333	295	283	251	231	205	210	186
4/0	378	335	321	284	261	231	237	210
250	414	367	351	311	285	253	258	229
300	458	406	387	343	313	277	284	252
350	499	442	420	372	339	300	307	272
400	537	476	451	400	364	323	329	291
500	607	538	507	449	408	361	369	327
600	669	593	558	494	447	396	404	358
750	754	668	626	555	500	443	451	400
900	832	737	687	609	547	485	492	436
1000	875	775	722	640	574	509	517	458
1250	978	867	803	711	635	563	572	507
1500	1065	944	870	771	687	609	617	547
1750	1140	1010	928	822	731	648	656	581
2000	1203	1066	976	865	767	680	689	610

**Notes:**

- (1) This table gives the allowable current for 90 °C rated single copper conductors with spacings installed in non-metallic underground raceways.
- (2) Underground ampacities for a conductor temperature of 75 °C may be obtained by multiplying the appropriate ampacity at 90 °C conductor temperature by the derating factor 0.886.
- (3) See Rule 4-006 for equipment termination temperature requirements.

**Table D9B**  
**Allowable aluminum conductor ampacities for cables**  
**rated not more than 5000 V and unshielded for the**  
**installation configurations of Diagram D9**

(see Rule 4-004.)

Size, AWG or Kcmil	1/phase, Detail 1		2/phase, Detail 2		4/phase, Detail 3		6/phase, Detail 4	
	90 °C	75 °C	90 °C	75 °C	90 °C	75 °C	90 °C	75 °C
1/0	199	176	171	152	141	125	128	113
2/0	226	200	194	172	159	141	145	128
3/0	257	228	219	194	179	159	163	144
4/0	293	260	249	221	203	180	184	163
250	321	284	272	241	221	196	201	178
300	355	315	300	266	243	215	221	196
350	386	342	326	289	264	234	239	212
400	416	369	351	311	283	251	256	227
500	471	417	395	350	318	282	288	255
600	521	462	435	385	350	310	316	280
750	590	523	491	435	392	347	354	314
900	652	578	540	478	431	382	388	344
1000	690	611	570	505	454	402	409	362
1250	783	694	643	570	509	451	458	406
1500	861	763	703	623	555	492	499	442
1750	930	824	757	671	596	528	536	475
2000	991	878	804	712	632	560	567	502

**Notes:**

- (1) This table gives the allowable current for 90 °C rated single aluminum conductors with spacings installed in non-metallic underground raceways.
- (2) Underground ampacities for a conductor temperature of 75 °C may be obtained by multiplying the appropriate ampacity at 90 °C conductor temperature by the derating factor 0.886.
- (3) See Rule 4-006 for equipment termination temperature requirements.



## D10 TABLES WITH 75° CALCULATIONS

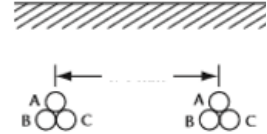

**Table D10A**  
**Allowable copper conductor ampacities for cables**  
**rated not more than 5000 V and unshielded for the**  
**installation configurations of Diagram D10**  
 (see Rule 4-004.)

Size,AWG or Kcmil	1/phase, Detail 1		2/phase, Detail 2		3/phase, Detail 3		4/phase, Detail 4		5/phase, Detail 5		6/phase, Detail 6	
	90 °C	75 °C	90 °C	75 °C	90 °C	75 °C	90 °C	75 °C	90 °C	75 °C	90 °C	75 °C
1 / 0	262	232	221	196	195	173	181	160	170	151	163	144
2 / 0	298	264	250	222	220	195	205	182	192	170	184	163
3 / 0	337	299	282	250	248	220	230	204	216	191	207	183
4 / 0	382	338	319	283	280	248	260	230	244	216	233	206
250	418	370	348	308	306	271	283	251	265	235	253	224
300	462	409	382	338	336	298	310	275	291	258	278	246
350	500	443	413	366	362	321	335	297	314	278	300	266
400	538	477	443	392	388	344	358	317	336	298	320	284
500	602	533	494	438	432	383	398	353	373	330	356	315
600	658	583	538	477	470	416	433	384	405	359	387	343
750	731	648	595	527	518	459	478	424	447	396	426	377
900	795	704	643	570	560	496	515	456	481	426	458	406
1000	827	733	669	593	582	516	535	474	500	443	476	422
1250	907	804	728	645	632	560	581	515	542	480	516	457
1500	966	856	772	684	670	594	615	545	574	509	546	484
1750	1017	901	809	717	702	622	643	570	600	532	571	506
2000	1060	939	840	744	728	645	667	591	622	551	591	524

**Notes:**

- (1) This table gives the allowable current for 90 °C rated copper conductor cables, or single copper conductors in contact, or multiplexed single copper conductors, directly buried in earth.
- (2) Underground ampacities for a conductor temperature of 75 °C may be obtained by multiplying the appropriate ampacity at 90 °C conductor temperature by the derating factor 0.886.
- (3) See Rule 4-006 for equipment termination temperature requirements.

**Table D10B**  
**Allowable aluminum conductor ampacities for cables**  
**rated not more than 5000 V and unshielded for the**  
**installation configurations of Diagram D10**  
 (see Rule 4-004.)

Size,AWG or Kcmil	1/phase, Detail 1		2/phase, Detail 2		3/phase, Detail 3		4/phase, Detail 4		5/phase, Detail 5		6/phase, Detail 6	
	90 °C	75 °C	90 °C	75 °C	90 °C	75 °C	90 °C	75 °C	90 °C	75 °C	90 °C	75 °C
1 / 0	203	180	172	152	152	135	141	125	132	117	127	113
2 / 0	230	204	193	171	171	152	159	141	149	132	143	127
3 / 0	261	231	219	194	193	171	179	159	168	149	161	143
4 / 0	298	264	249	221	219	194	203	180	190	168	182	161
250	324	287	270	239	238	211	220	195	207	183	197	175
300	359	318	298	264	262	232	242	214	227	201	217	192
350	390	346	323	286	284	252	262	232	246	218	235	208
400	419	371	347	307	304	269	281	249	263	233	251	222
500	473	419	389	345	340	301	314	278	294	260	281	249
600	522	462	428	379	374	331	345	306	323	286	308	273
750	586	519	478	424	417	369	384	340	359	318	342	303
900	643	570	522	462	455	403	418	370	391	346	373	330
1000	677	600	548	486	477	423	439	389	410	363	391	346
1250	757	671	608	539	528	468	485	430	453	401	431	382
1500	819	726	655	580	568	503	521	462	487	431	463	410
1750	873	773	695	616	602	533	552	489	515	456	490	434
2000	917	812	727	644	630	558	577	511	538	477	512	454

**Notes:**

- (1) This table gives the allowable current for 90 °C rated aluminum conductor cables, or single aluminum conductors in contact, or multiplexed single aluminum conductors, directly buried in earth.
- (2) Underground ampacities for a conductor temperature of 75 °C may be obtained by multiplying the appropriate ampacity at 90 °C conductor temperature by the derating factor 0.886.
- (3) See Rule 4-006 for equipment termination temperature requirements.



## D11 TABLES WITH 75° CALCULATIONS

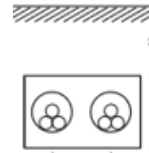

**Table D11A**  
**Allowable copper conductor ampacities for cables**  
**rated not more than 5000 V and unshielded for the**  
**installation configurations of Diagram D11**

(see Rule 4-004.)

Size,AWG or Kcmil	1/phase, Detail 1		2/phase, Detail 2		3/phase, Detail 3		4/phase, Detail 4		5/phase, Detail 5		6/phase, Detail 6		8/phase, Detail 8	
	90 °C	75 °C	90 °C	75 °C	90 °C	75 °C	90 °C	75 °C	90 °C	75 °C	90 °C	75 °C	90 °C	75 °C
1 / 0	205	182	185	164	169	150	158	140	147	130	139	123	130	115
2 / 0	233	206	210	186	192	170	179	159	166	147	157	139	147	130
3 / 0	266	236	239	212	218	193	202	179	188	167	178	158	166	147
4 / 0	303	268	271	240	247	219	229	203	212	188	201	178	187	166
250	335	297	298	264	271	240	251	222	232	206	219	194	204	181
300	370	328	329	291	298	264	276	245	255	226	241	214	224	198
350	403	357	357	316	323	286	299	265	276	245	261	231	242	214
400	434	385	384	340	347	307	320	284	295	261	279	247	259	229
500	489	433	430	381	388	344	357	316	329	291	310	275	288	255
600	539	478	472	418	424	376	390	346	359	318	339	300	314	278
750	601	532	524	464	470	416	431	382	397	352	374	331	346	307
900	655	580	569	504	509	451	466	413	428	379	403	357	373	330
1000	683	605	593	525	530	470	485	430	445	394	419	371	388	344
1250	752	666	649	575	578	512	528	468	484	429	455	403	421	373
1500	804	712	691	612	614	544	561	497	513	455	482	427	445	394
1750	847	750	726	643	644	571	587	520	537	476	504	447	466	413
2000	901	798	744	659	659	584	601	532	549	486	515	456	476	422

**Notes:**

- (1) This table gives the allowable current for 90 °C rated multiple copper conductor cables, or single copper conductors in contact, or multiplexed single copper conductors, installed in underground raceway.
- (2) Underground ampacities for a conductor temperature of 75 °C may be obtained by multiplying the appropriate ampacity at 90 °C conductor temperature by the derating factor 0.886.
- (3) See Rule 4-006 for equipment termination temperature requirements.

**Table D11B**  
**Allowable aluminum conductor ampacities for cables**  
**rated not more than 5000 V and unshielded for the**  
**installation configurations of Diagram D11**

(see Rule 4-004.)

Size,AWG or Kcmil	1/phase, Detail 1		2/phase, Detail 2		3/phase, Detail 3		4/phase, Detail 4		5/phase, Detail 5		6/phase, Detail 6		8/phase, Detail 8	
	90 °C	75 °C	90 °C	75 °C	90 °C	75 °C	90 °C	75 °C	90 °C	75 °C	90 °C	75 °C	90 °C	75 °C
1 / 0	157	139	143	127	131	116	122	108	114	101	108	96	101	89
2 / 0	179	159	162	144	148	131	138	122	129	114	122	108	114	101
3 / 0	205	182	184	163	168	149	157	139	146	129	138	122	129	114
4 / 0	235	208	210	186	192	170	178	158	165	146	156	138	146	129
250	258	229	231	205	210	186	195	173	180	159	171	152	159	141
300	286	253	255	226	232	206	215	190	199	176	188	167	175	155
350	312	276	278	246	252	223	233	206	215	190	204	181	189	167
400	337	299	299	265	271	240	250	222	231	205	218	193	203	180
500	382	338	337	299	305	270	281	249	259	229	245	217	227	201
600	424	376	373	330	336	298	309	274	285	253	269	238	249	221
750	478	424	419	371	376	333	346	307	318	282	300	266	278	246
900	527	467	459	407	412	365	378	335	347	307	327	290	303	268
1000	555	492	483	428	433	384	397	352	364	323	343	304	318	282
1250	626	555	541	479	482	427	441	391	404	358	380	337	351	311
1500	679	602	585	518	520	461	475	421	435	385	409	362	377	334
1750	724	641	621	550	552	489	503	446	461	408	432	383	399	354
2000	777	688	646	572	573	508	522	462	477	423	448	397	413	366

**Notes:**

- (1) This table gives the allowable current for 90 °C rated multiple aluminum conductor cables, or single aluminum conductors in contact, or multiplexed single aluminum conductors, installed in underground raceway.
- (2) Underground ampacities for a conductor temperature of 75 °C may be obtained by multiplying the appropriate ampacity at 90 °C conductor temperature by the derating factor 0.886.
- (3) See Rule 4-006 for equipment termination temperature requirements.





## 4-004 – AMPACITY OF WIRES AND CABLES (SEE APPENDIX B)

Note – Table 39 has now been deleted. This requires that all service conductor calculations performed in accordance with section 8 shall be sized as per this rule (e.g., Tables 1-4 or the D tables).

## 4-006 - TEMPERATURE LIMITATIONS (SEE APPENDIX B)

Where a conductor is terminated on equipment with a 60°C or 75°C rating, the maximum conductor ampacity shall be based on the 60°C or 75°C column of Tables 1, 2, 3 or 4.

When equipment termination temperature rating is not marked on the equipment, it shall be:

### **60°C for equipment:**

- rated not more than 100 A; or
- marked for use with a No. 1 AWG or smaller conductor; and

### **75°C for equipment:**

- rated more than 100 A; or
  - marked for use with conductors larger than No. 1 AWG.
- All relevant correction factors being determined from Rule 4-004, such as Table 5A, will apply to ampacity rating from the equipment termination temperature rating **not** the insulation temperature rating when the equipment termination temperature rating is required to be used.
  - For high voltage equipment's termination temperature rating when not marked, consult the manufacturer, and provide documentation to the Electrical Inspections department.
  - Equipment termination temperature rating applies to the first 1.2 m (4') of conductor from the connection point on the equipment.

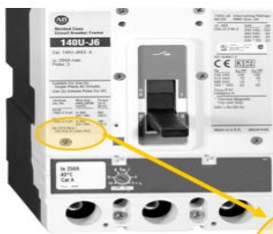

“60/75 °C Wire –  
125 Amp & Lower Only”



When not listed,  
refer to  
Rule 4-006(2)(a)(b)



“Use 75 Degrees C  
conductors”

## △ 4-008 - INDUCED VOLTAGES AND CURRENTS IN METAL ARMOUR OR SHEATHS OF SINGLE CONDUCTOR CABLES (SEE APPENDIX B)

Where sheath currents are likely to cause insulation of the conductors to be subjected to temperatures in excess of the insulation ratings, the cables shall be:

- a) derated to 70% of the cable ampacity,
- b) derated in accordance with manufacturers recommendations and 2-030,
- c) Installed in a manner that prevents the flow of sheath currents.

Includes the use of non-ferrous metals when encircling the conductors to deal with the magnetic and hysteresis effects, i.e. clamps, straps, connectors, KO's...

1c TECK90 w/ concentric bond conductor, 1c ACWU90 w/concentric bond conductor, 1c CORFLEX RA90 w/ continuous corrugated welded aluminum sheath armour. These bonding paths shall all be treated the same as far as bonding or isolating requirements. For 5KV and above, see Table D17 Conditions of use or manufacturers recommendations.

Above 425 A or whenever a single bonding conductor is installed, it should be installed as per manufacturers recommendations.

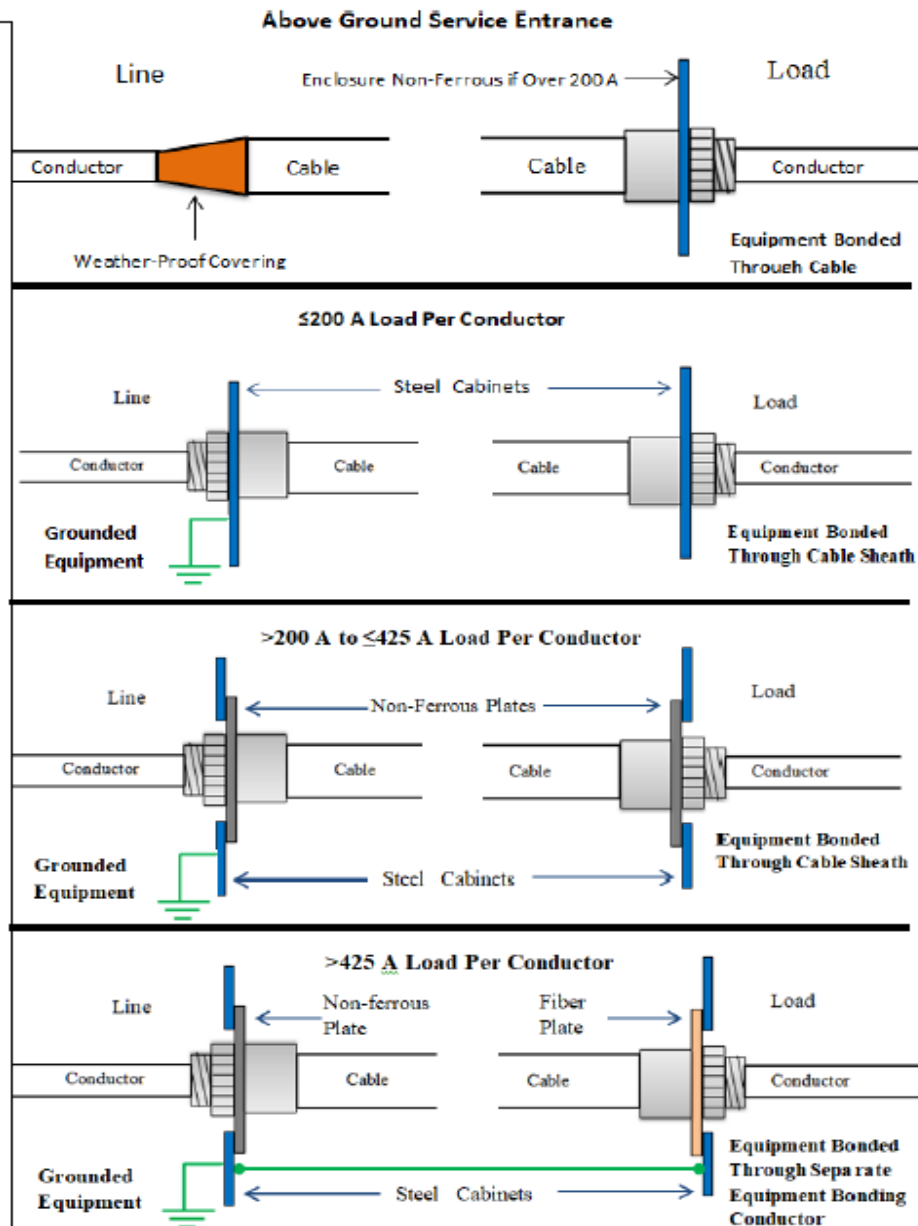

## 4-022 - INSTALLATION OF IDENTIFIED CONDUCTORS (SEE APPENDIX B)

4-022(1) Where a service, feeder or branch circuit requires an identified conductor, it shall be installed.

4-022(2) The neutral conductor shall be installed at each switch controlling permanently installed luminaires at a branch circuit outlet.

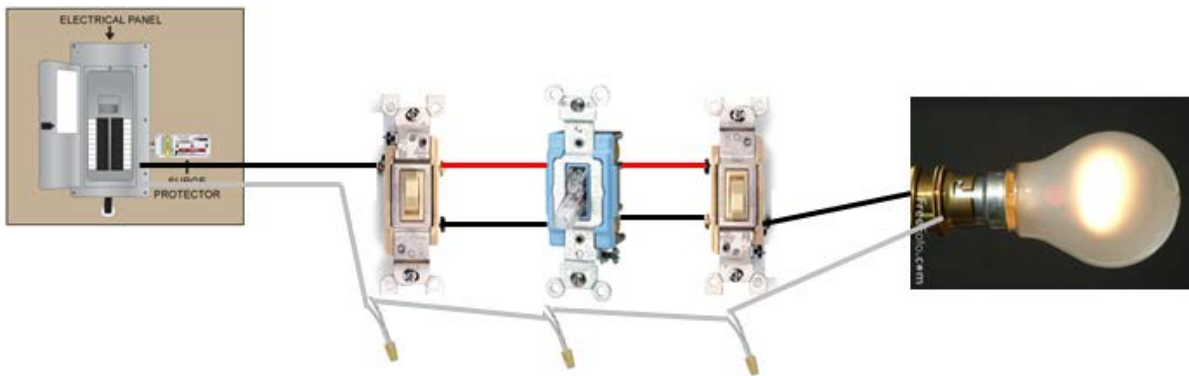

## 4-032(3) - IDENTIFICATION OF INSULATED CONDUCTORS

Unless specified elsewhere in the code, colour coding of branch circuit conductors and service conductors are not a mandatory requirement. This rule states that where colour coding is required, the colours shall be red, black, and blue. The utility electric service requirements may specify where conductors must be colour coded (splitter box or CT metering). If CT metering is used after the main disconnect, then colour coding must be used to that point.

## SECTION 6 – SERVICES AND SERVICE EQUIPMENT

### 6-104 - NUMBER OF CONSUMER'S SERVICES PERMITTED IN OR ON A BUILDING

The maximum number of consumer services from a single supply service is four. **The contractor must confirm the installation with the local utility and meet utility requirements prior to construction.**

**NOTE:** If two supply services are permitted, then they will require a label at each service, stating that there are two services and the location of each.

### 6-112 - SUPPORT FOR THE ATTACHMENT OF OVERHEAD SUPPLY OR CONSUMER'S SERVICE CONDUCTORS OR CABLES (SEE APPENDIX B)

**6-112(3)** - For the purpose of this rule 'ground normally accessible to pedestrians' includes patios and decks.

6-112(5) Appendix B - note states an acceptable manner for mast support is one where three (3) support clamps are used, of these, the upper most is required to be a complete through bolt assembly consisting of a minimum 12 mm bolt, nut, and washer, and an insulated point of connection.

As an alternative to the "through bolt" requirement, **with the permission of the Local Electrical Inspector**, a unistrut support may be allowed to be lag bolted to the exterior of the building (into structural members) for mast support. A rigid 2-hole strap and spring nuts shall be used on the mast to secure it to the unistrut. **This may be allowed on a case-by-case basis, after review and acceptance by the Local Electrical Inspector.** It should only be considered when it is impractical or impossible to install the normal through bolt support. Must be an insulated point of connection.

### 6-200(1) - SERVICE EQUIPMENT - SINGLE BREAKER SERVICE EQUIPMENT

Each consumer's service shall be provided with a single service box, except where a panelboard can employ no more than two single-pole breakers, one two-pole breaker, or one three-pole breaker and is **service entrance rated**.

### △ 6-200(2) - SERVICE EQUIPMENT – DUAL-LUG METER SOCKETS (SEE 6-104)

200 A dual-lug meter sockets, 400 A or 600 A customer service termination equipment (CSTE) cabinets may be installed where a customer wants multiple consumer services and is acceptable to the utility. The subdivision of the consumer services can be accomplished within the dual-lug meter socket or CSTE cabinet provided that the total current rating of the consumer service disconnects does not exceed the ampere rating of the meter socket or CSTE cabinet.

In rural areas where a 400 A or 600 A CSTE cabinet is used, a service entrance rated disconnect(s) is required within 3 M of the CSTE cabinet. (E.g., 1 - 400 A, 2 - 200 A, or 4 - 100 A.)

## △ 6-206 - CONSUMER'S SERVICE EQUIPMENT LOCATION

### 6-206(1)(a) - Electric Service Requirements

Contractor must ensure the service meets utility service requirements prior to energization. Contractor shall enquire at relevant utility provider. Online resources are:

- SaskPower Electric Service Requirements can be found online at [www.saskpower.com](http://www.saskpower.com) or call SaskPower at 1-888-757-6937.
- City of Saskatoon – [www.saskatoon.ca](http://www.saskatoon.ca) - Saskatoon Light & Power - Service Guide.
- City of Swift Current - Use SaskPower Electric Service Requirements.

### 6-206(1)(c) - Panels

Thermally insulated walls are considered an undesirable location for recessing of panelboards.

Panelboards shall be installed in the building being served and the length of unfused service conductors shall not exceed six (6) conduit meters (20'). Where the service box or other consumer's service equipment is located beyond six (6) conduit meters (20') from the point where unfused service conductors enter the building, the conductors shall be run in threaded rigid metal conduit for the entire length inside the building.

**NOTE:** Metallic service conduits or service cables with metallic armor require a bonding bushing in the main service to assure continuity of the raceway or sheath. See [10-604](#) - assuring bonding continuity at service equipment.

### 6-206(3) - Service disconnect

The service disconnecting means shall be service entrance rated and permitted to be placed on the outside of the building or on a pole, provided it is rated for the location and protected from damage in accordance with the CEC requirements.

Except for extra low voltage sites (e.g., 12-volt DC), each oil well site or string of wells, shall be provided with a service entrance rated single point of disconnect and the feeder conductors shall also include a bond conductor sized to Table 16 to safely conduct any fault current back to the source and to ensure the safe operation of the overcurrent devices.

#### NOTES:

- An oil field well controller shall not be considered a service disconnect unless service entrance rated.
- The SaskPower supplied farm service center ('F' cabinet) breaker shall not be considered as overcurrent protection for the service or cables.
- 480-Volt utility service meter cabinets **shall only** be operated by Utility Personnel. (i.e., Oil Field, Irrigation Pivots, etc.)

## 6-208 - CONSUMER'S SERVICE CONDUCTORS' LOCATION - UNDER HOUSE TRAILER/MOBILE HOMES

Service conductors installed underneath a house trailer/mobile home must be approved for the location and supported to the underside of the mobile home or buried. Unarmored service conductors must be installed in a raceway from the point where they issue from the earth and include a bond as per Section 10.

For the purposes of 6-206(1)(c), the 6 m (20') rule does not apply to underneath the mobile home.

## 6-212 -WIRING SPACE IN ENCLOSURES

Where a service **disconnecting means** is not equipped with a barrier between the line and load side, the conductors shall enter the service box as close as possible to the line terminals and not come into contact with or cross conductors connected to the load terminals.

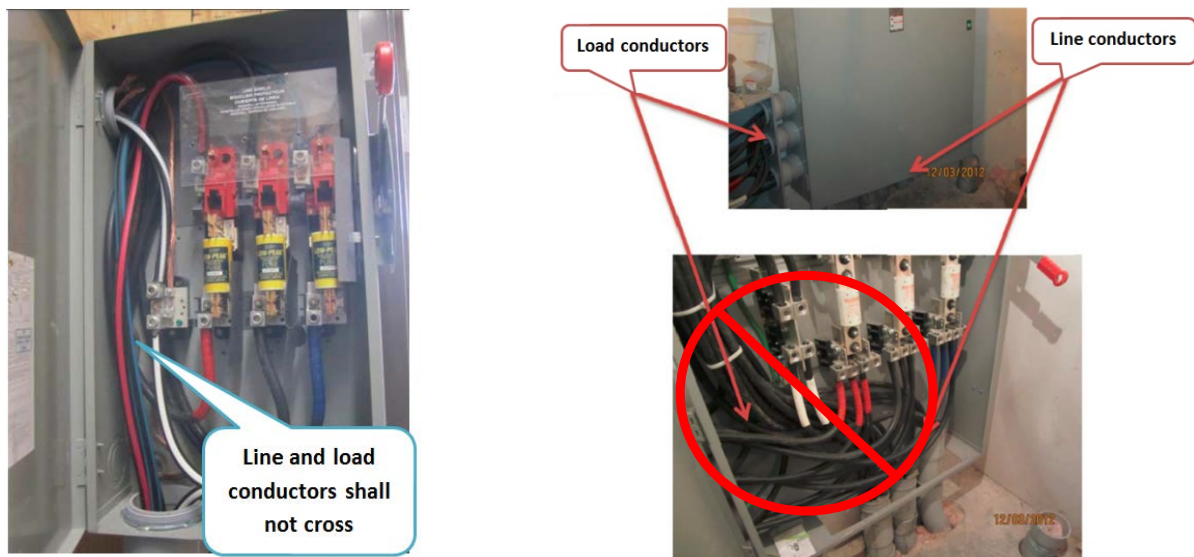

### NOTE:

The bonding conductor for water line, gas line etc. shall not be taken out of the main disconnect area of a combination breaker panel.

## 6-300 - INSTALLATION OF UNDERGROUND CONSUMER'S SERVICE CONDUCTORS

Caution must be taken by the electrical contractor when installing a customer owned underground service from the meter socket to the panelboard location.

The consumer's underground cable must be installed tight to the basement wall anywhere within 1.5 m (5') of the meter socket location. This will help to prevent the cable from being damaged when the utility trenches in their underground service cable from the pole or pedestal to the socket. Once the cable is past the 1.5 m (5') distance, it may then be installed out away from the basement wall. Cables without mechanical protection shall be in 150mm (6") of sand or in a conduit to protect it from damage and settling during back fill.

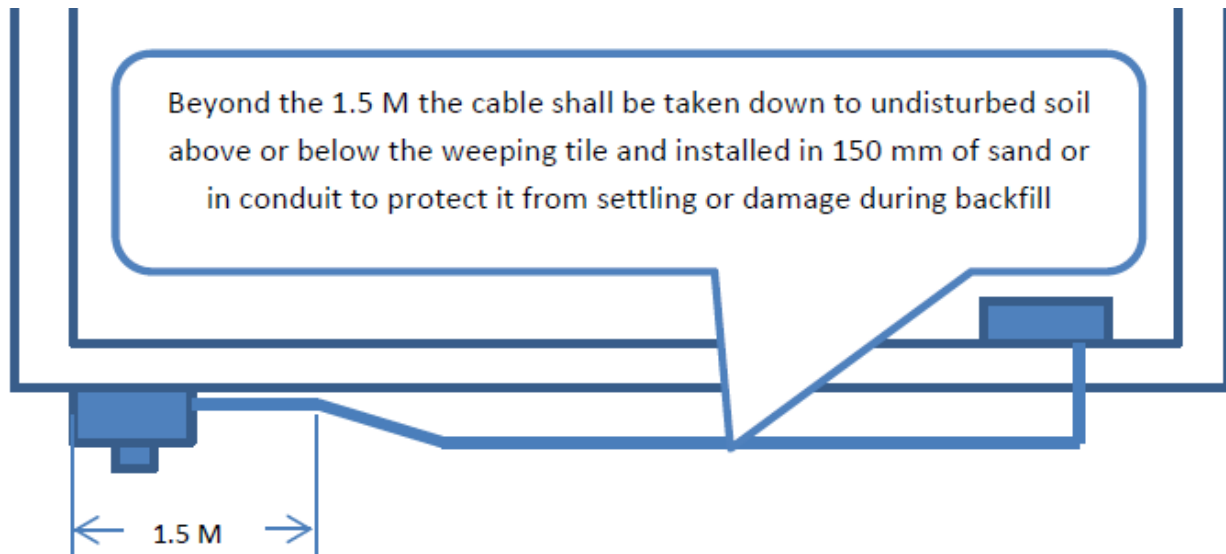

As per [12-012](#) (11) & (12), the installation will also require frost sleeves at both ends and marking tape must be installed in the cable trench.

Underground service entrance cable as described in Table 19 shall be allowed to be supplied from a branch circuit overcurrent device when used as an underground feeder. The bare conductor (USEB) cannot be used as a neutral unless effectively isolated. USEI and USEB require mechanical protection installed where exposed above ground.

### 6-312 - CONDENSATION IN CONSUMER'S SERVICE RACEWAY

It is recommended that the sealing be performed on the warm side to prevent condensation build-up in the conduit. Conduit may be sealed on both the warm and the cold side.

### 6-404 - ENCLOSURES FOR INSTRUMENT TRANSFORMERS

Where required for metering only, the neutral must be brought into the CT cabinet, sized and terminated to meet metering requirements as per local utility service requirements. Consult utility.

### △ 6-408(1)(f) – LOCATION OF METERS (NOTE DELETED)

## SECTION 8 – CIRCUIT LOADING AND DEMAND FACTORS

### 8-102 - VOLTAGE DROP

Precautions must be taken to prevent any services or branch circuits from exceeding 5% voltage drop from the utility to the end use, with no feeder or branch circuit exceeding 3%. The calculation of voltage drop on services and branch circuits is based on the connected load, or 80% of the overcurrent device for unknown loads. See CEC Rule 8-102, Table D-3 and Handbook for clarification and examples.

Voltage Drop Calculators (apps or websites) may be acceptable for deriving calculations however it is the sole discretion of the local Electrical Inspector if they agree with the numbers provided and have the ability to request evidence as they see fit.

#### Formula

$$L = L_t \times P \times DCF \times (V / 120)$$

where

L = the distance to the centre of distribution in metres given in Table D3 for 1% voltage drop at 120 V

L<sub>t</sub> = the maximum distance to the centre of distribution in metres

P = the voltage drop percent required in the circuit

DCF = the distance correction factor given in Note 3) to Table D3

V = the voltage required by the load

Table D3

Note:

3) Because the distances in Table D3 are based on conductor resistances at 60 °C, these distances must be multiplied by the correction factors below according to the temperature rating of the conductor insulation used and the percentage load with respect to the allowable ampacity. Where the calculation and the allowable ampacity fall between two columns, the factor in the higher percentage column must be used.

Rated conductor insulation temperature	Distance correction factor						
	Percentage of allowable ampacity						
	100	90	80	70	60	50	40
60 °C	1.00	1.02	1.04	1.06	1.07	1.09	1.10
75 °C	0.96	1.00	1.00	1.03	1.06	1.07	1.09
85–90 °C	0.91	0.95	1.00	1.00	1.04	1.06	1.08
110 °C	0.85	0.90	0.95	1.00	1.02	1.05	1.07
125 °C	0.82	0.87	0.92	0.97	1.00	1.04	1.07
200 °C	0.68	0.76	0.83	0.90	0.96	1.00	1.04

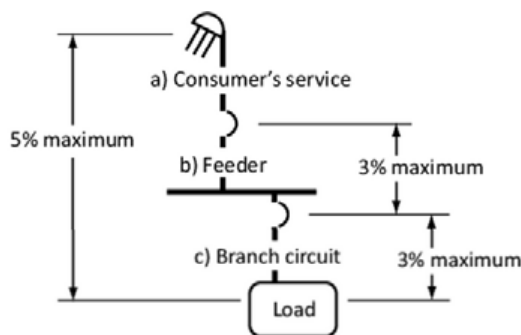



## △ 8-104 - MAXIMUM CIRCUIT LOADING (SEE APPENDIX B)

1. Where single conductor cables are used, they are permitted to be smaller in size due to the installation methods. Where they rise to terminate on a breaker, the heating in the enclosure can exceed the rating of the conductor. This is the reason that the single conductor cables need to be derated further.
2. Where a fused switch or circuit breaker is marked for continuous operation at 80% or 100% the rating of the respective cables will also change as per the CEC requirements. The continuous load as determined from the calculated load shall not exceed the continuous operation marking on the fused switch or circuit breaker. The continuous load may however be less due to the allowable ampacities of the conductors and the deration required by this rule.
3. Where the maximum continuous load allowed on a fused switch or circuit breaker as determined from Rule 8-104 (5) & (6) is less than the continuous operating marking of the fused switch or circuit breaker, a permanent, legible caution label shall be installed adjacent to the fused switch or circuit breaker to indicate the maximum continuous load permitted.
4. Installation or addition of a vehicle charging system shall not exceed the building feeder or service loading requirements. See also 8-500 (2).

Labels shall be in accordance with 2-100.

### 8-104(3)(A) - WATER HEATERS

Water heaters are considered continuous loads and, therefore, the circuit conductor and the overcurrent device shall be loaded to a maximum of 80%. Example - if the water heater is rated at 3000 watts on 240 V (12.5 A), 62-114(7) will allow a #14 AWG conductor and a 20 A breaker.

## △ 8-106 - USE OF DEMAND FACTORS

8-106(10) is to be used where electric vehicle supply equipment loads are controlled by an electric vehicle energy management system (EVEMS).

8-106(11) is to be used where the system monitors the service and feeders and controls the electric vehicle supply equipment loads in accordance with 8-500. Then the demand load for the electric vehicle equipment is not required to be considered in determining the calculated load.

### NOTES:

- The 5% rule for conductor selection has been deleted. Please refer to [14-104](#) to assist in selection of overcurrent protection in relation to the conductor ampacity rating based on the calculated load.
- Unless allowed by other rules of this code the conductors must be rated for the ampacity of the O/C protection.
- Labelling requirements as per 2-100.
- See Table 38 for (EVEMS) equipment demand factors.

## SECTION 10 – GROUNDING AND BONDING

### 10-000 - SCOPE

Grounding and bonding installations shall conform to the drawings provided by the Electrical Inspections department Interpretations Figures 10-1 to 10-8. The Appendix B drawings may be followed under special permission.

### 10-004 - SPECIAL TERMINOLOGY

- Equipotentiality - This is a new definition introduced into the code to describe the state in which conductive parts are at a substantially equal electric potential.
- Grounding - a permanent conductive path to earth. Sometimes referred to as 'earthing' this accomplishes system stabilization and establishes an equipotential plane in the surrounding soil.
- Bonding - a low impedance path obtained by joining all non-current carrying metal parts to ensure electrical continuity and having the capacity to conduct safely any current likely to be imposed on it and to facilitate the operation of the protective (overcurrent...) device in the circuit. Also creates equipotentiality between all metallic parts.
- Grounded conductor - is now defined in the code as the conductor that is intentionally grounded in a system.
- System bonding jumper - is the connection between the electrical systems' grounded point (neutral) and the non-current-carrying conductive parts (metal enclosure, raceways etc.) of the electrical system to establish a solidly grounded system.
- Single point system grounding - is the connection of the system neutral or grounded system conductor to a ground electrode at one point only. This connection shall be made as close to the source as possible.

### 10-100 & 10-500 - CURRENT OVER GROUNDING AND BONDING CONDUCTORS

For the purposes of Rules 10-100 & 10-500, the term 'objectionable flow of current' shall be defined as "any current that flows over conductors for which they were not intended and/or designed to accommodate, such as neutral current over bonding and/or grounding conductors, or neutral current over metallic piping". Caution shall be exercised to prevent this situation from occurring.

#### **Municipal water line replacement programs**

Where municipalities are upgrading the water systems, any neutral currents flowing on the water lines from faulty system grounding may result in a shock hazard. All residences fed from any transformers showing signs of neutral current on the water lines, need to have their utility systems checked, grounding systems upgraded and repaired to create a safe installation prior to water line replacement.



## 10-102 - GROUNDING ELECTRODES

Underground metallic water lines **shall not** be used as a grounding electrode. Any existing ground connection to the water line shall be removed when upgrading the services. A tag stating '**WARNING POSSIBLE SHOCK HAZARD**' shall be installed at the water meter. Please contact your Local Inspector for tags as required. See Figure 10-1:

△



Figure 10-1

## 10-108 - LIGHTNING PROTECTION SYSTEM DOWN CONDUCTORS AND GROUNDING ELECTRODES (SEE APPENDICES B & G)

Recommended practices for the installation of a lightning protection system, including lightning rods, interconnecting conductors, and ground electrodes, are given in CAN/CSA-B72. Other national and international industry-recognized standards on lightning protection may also be available.

As per Rule 12-016 where lightning down conductors are installed, electrical wiring shall, where practicable, be kept at least 2 m (6') from such conductors and installed at or below ground level in accordance with Rule 10-104.

**NOTE:** Lightning protection system installations are to be installed by a licensed contractor and require an electrical permit.

## 10-112 - MATERIAL FOR GROUNDING CONDUCTORS (SEE APPENDIX B)

Bare aluminum shall not be installed in corrosive locations such as direct earth burial or masonry.

## 10-116(1) - INSTALLATION OF GROUNDING CONDUCTORS

The grounding connection shall be **electrically continuous** throughout its length. This can be accomplished through approved split bolts, lugs, etc.

## 10-210 - GROUNDING CONNECTIONS FOR SOLIDLY GROUNDED AC SYSTEMS SUPPLIED BY THE SUPPLY AUTHORITY (SEE APPENDIX B)

- △
- 1) To meet the intent of 10-002 in establishing equipotentiality between bonded equipment and the nearby surfaces of the earth, there shall be an electrode installed and grounding conductor connected to the non-current carrying parts of electrical equipment at all facilities, buildings, or structures supplied with electrical panels or sub-panels. See [Figure 10-2](#).
  - 2) Customer owned service conductors supplied and installed by the electrical contractor shall include a separate neutral, where required, and bonding conductors. See [Figure 10-2](#). The neutral conductor, where required, shall be insulated, and remain isolated beyond the connection to the source. See [Figure 10-2](#).
  - 3) Where separate neutral and bonding conductors are not installed, the neutral/grounded system conductor shall be connected to ground either directly to the facility electrode or through the system bonding jumper. This connection shall be made at the first point of attachment or connection of the supply service conductors.
  - 4) This connection shall be made at only one point and the neutral conductor shall be insulated and isolated from the grounding and bonding systems, metallic equipment, and metallic surfaces beyond this connection. See [Figure 10-4, 10-5 & 10-5a](#).
  - 5) For overhead services, the neutral conductor shall be insulated, and the grounding connection shall be made at the meter socket. Point of connection shall be insulated. See [Figure 10-4](#).
  - 6) Where a neutral conductor is not required (there are no neutral loads being served), a bonding conductor shall be installed to facilitate the fault return. The supply authority may require a neutral conductor to satisfy the metering requirements.

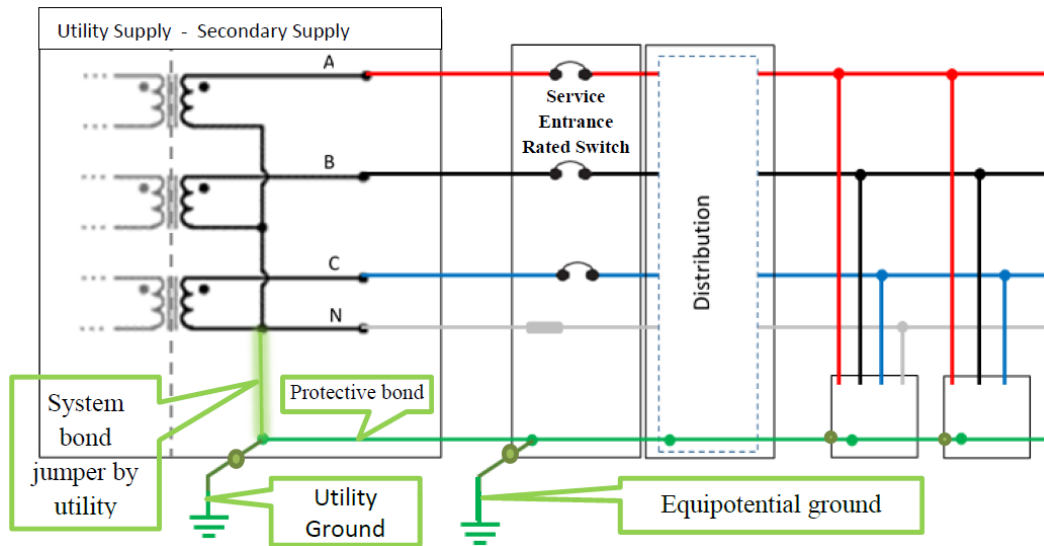

**NOTE:** Utility owned transformer is grounded, and the system bond jumper is installed in accordance with utility standard, the protective bond is sized as per Table 16 based on the ungrounded conductor ampacity per 10-614(2) and is carried with the main conductors to the service entrance switch. All other equipment grounding is for the purpose of establishing an equipotential plane.

Figure 10-2

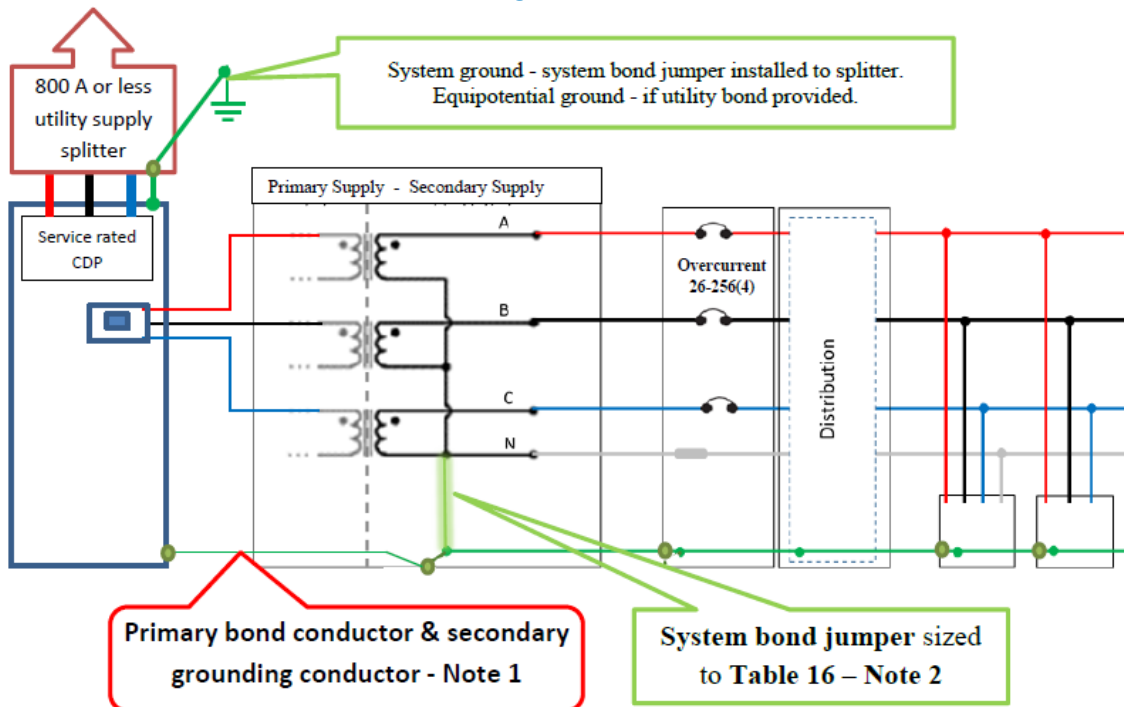

**NOTE 1:** The bond conductor run with the primary feeder for a separately derived system is sized sufficiently to also function as the secondary ground per [10-212\(2\)](#).

**NOTE 2:** The system bond jumper per 10-614 App B must be sized to the secondary of the transformer based on the current from primary overcurrent device rating multiplied by the primary to secondary voltage ratio.

Figure 10-3



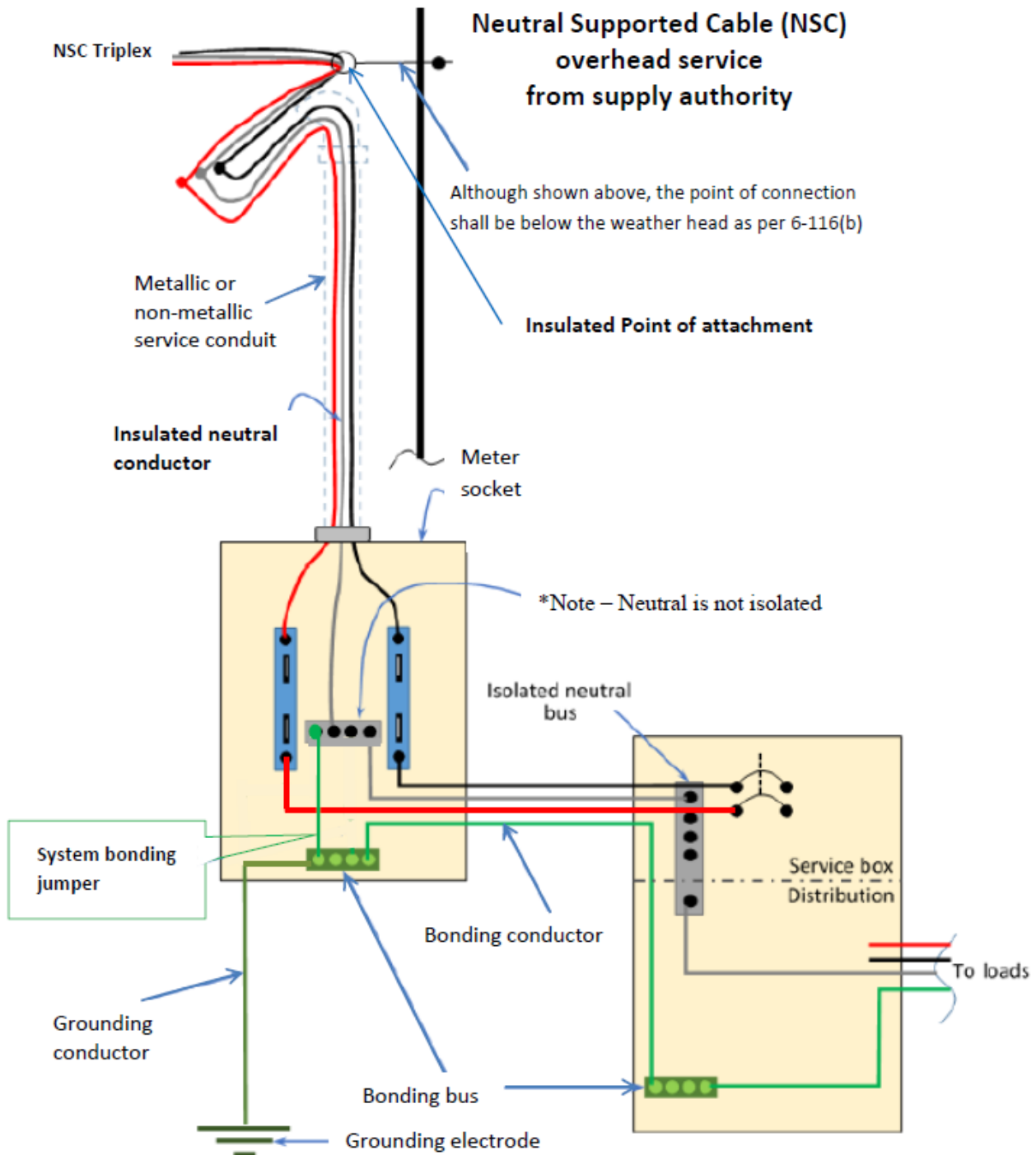

**NOTE:** This wiring method shall be used for overhead services, the neutral supported cable shall be isolated from the point of connection with an insulator and the customer service neutral shall be insulated in the service raceways and mast.

Figure 10-4

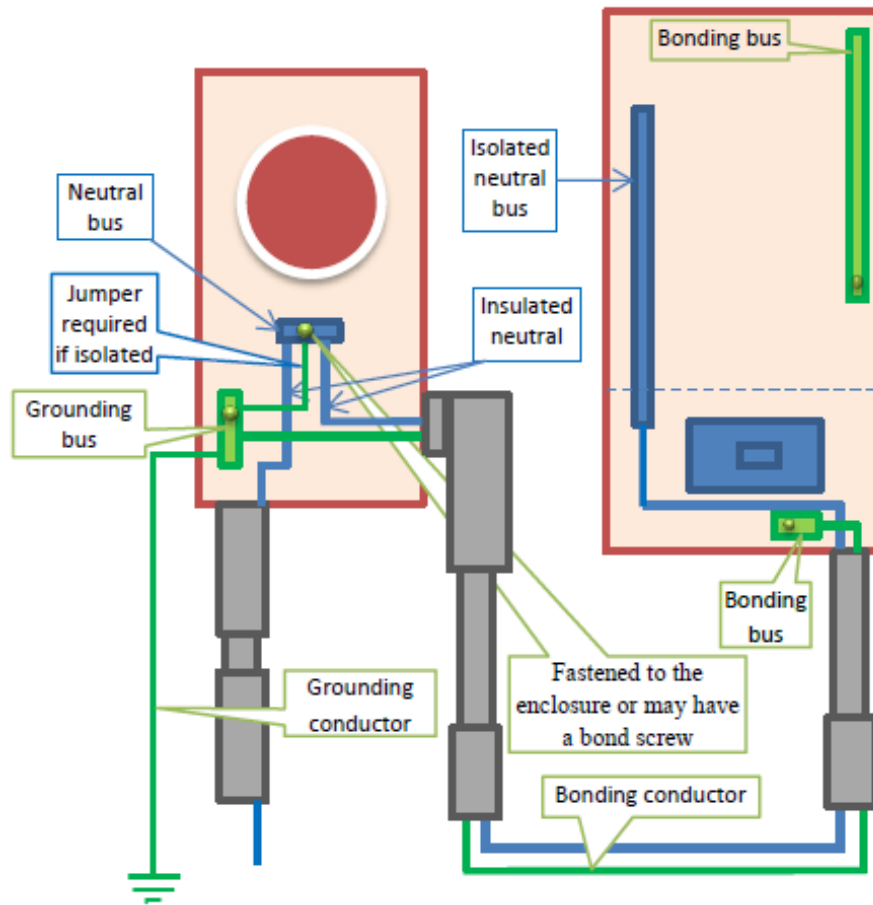

**NOTE:** This is the current method when the utility does not supply an underground bond conductor. The neutral is re-grounded at the customer meter and isolated beyond that point.

Figure 10-5

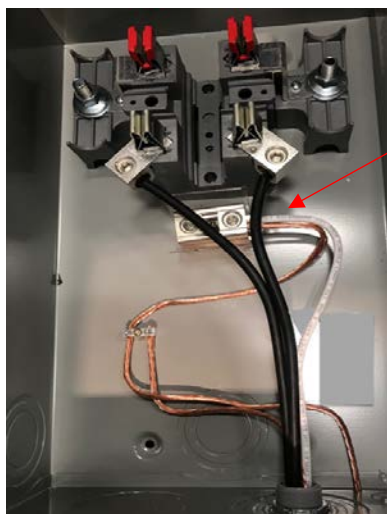

**NOTE:** This installation must have the neutral grounded in the meter socket. If installed with an isolated neutral bus in the meter socket it must have a system bonding jumper installed.

Figure 10-5a

## Δ 10-212(2) - GROUNDING CONNECTIONS FOR SOLIDLY GROUNDED SEPARATELY DERIVED SYSTEMS

The bonding conductor in the primary feed to a transformer enclosure will meet the requirements of the grounding conductor for the X0 on the secondary side of the transformer.

The system bonding jumper (see 10-004 & 10-614 App B) shall be sized as per Table 16 based on the secondary current of the transformer which is determined by the primary overcurrent protection device rating multiplied by the primary to secondary voltage ratio and connected to the enclosure to satisfy the requirement for the secondary fault return current and the grounding requirement.

See [Figure 10-3](#) and the [3 Phase Dry Core Transformer Tables](#).

## Δ 10-302(2)&(3) - USE (SEE APPENDIX B) – IMPEDANCE GROUNDED SYSTEM

Impedance grounded systems require the grounding circuit to be electrically continuous and monitored. This includes the connections from the X0 through the impedance device and the impedance system bonding jumper to the grounding conductor connection. See [Figure 10-6](#).

The integrity of the impedance grounding system shall be monitored with an audible or visual alarm, shall be visible to persons monitoring the status of the system and labeled:

‘CONTACT \_\_\_\_\_ IF THE SYSTEM IS IN ALARM’. See Table 17.

## Δ 10-308 - CONDUCTORS USED WITH IMPEDANCE GROUNDING DEVICES (SEE APPENDIX B)

Where the system is not serving neutral loads, the conductor connecting the impedance grounding device to the neutral point of the system source shall meet the requirements of this Rule and shall not be installed to the main switchgear, unless otherwise required for metering purposes or installation to the impedance grounding device. This neutral shall not be distributed and shall be labelled at each termination point to indicate “NOT FOR NEUTRAL LOADS”.

Impedance grounded systems are not solidly grounded systems. The conductor from the transformer/source to the impedance device must take the most direct route and is not required to enter the main service disconnect. This Rule provides several conditions that must be met regarding this conductor. The minimum conductor size is now #12 AWG copper or #10 AWG aluminum conductors.

The path from the neutral point through the impedance grounding device to the system grounding electrode shall be electrically continuous and monitored as per 10-302 and Table 17. See [Figure 10-6](#).

## 10-400 - UNGROUNDED SYSTEMS

Ground fault indication activated by a ground fault shall be visible to persons monitoring the status of the system and labeled ‘CONTACT \_\_\_\_\_ IF LIGHT IS OUT OR SYSTEM IS IN ALARM’.

Regardless of other monitoring systems being implemented, each installation shall have fault indication lights and/or audible alarm. Installation conditions may dictate that both systems may be required (i.e., site conditions, noise levels, etc.).



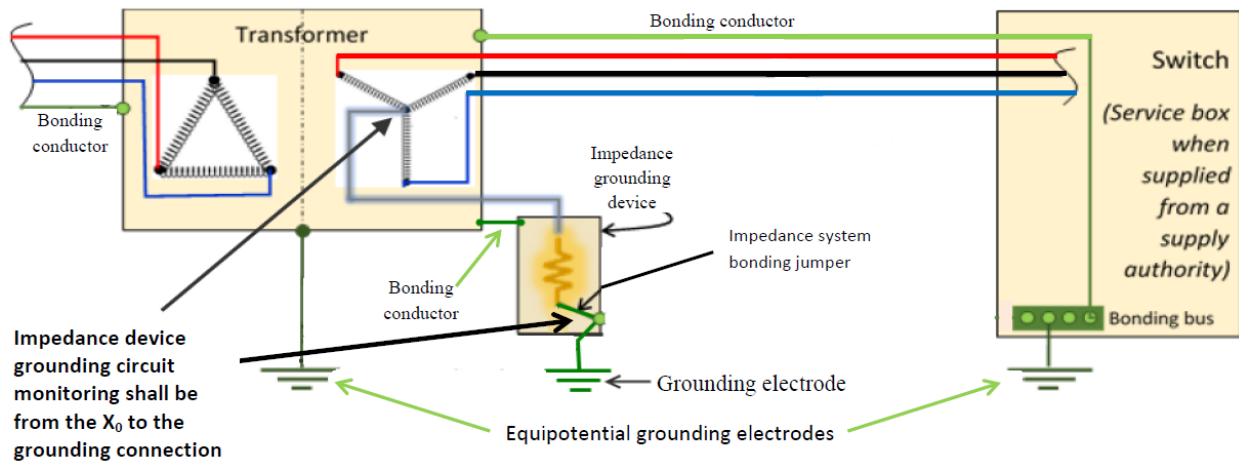

The impedance grounded circuit shall be monitored from the  $X_0$  to the connection to the grounding electrode.

Figure 10-6

### △ 10-604 - BONDING CONTINUITY FOR SERVICE EQUIPMENT

- 1) The bonding continuity for service equipment shall be assured by bonding means prescribed in Rule 10-610.
- 2) Standard locknuts serving as the bonding means for metal raceway, metal sheath, or cable armour connecting to service equipment shall be supplemented by bonding bushings with a bonding conductor connecting to a bonding bus within the enclosure
  - a) at both ends where the metal raceway, metal sheath, or cable armour serves as the bonding means between service equipment; or
  - b) at one end where
    - i) a bonding conductor is run with circuit conductors; or
    - ii) the termination to service equipment is only at one end.
- 3) Notwithstanding Subrule 2), bonding bushings shall not be required for cable assemblies incorporating an internal bonding conductor in continuous contact with the cable armour, provided that the internal bonding conductor extends from the cable and connects to the service equipment.

### 10-616 - SIZE OF SYSTEM BONDING JUMPER OR BONDING CONDUCTOR (SEE APPENDIX B)

- 1) The size of a field-installed system bonding jumper shall not be less than that determined by the application of Table 16 based on the ampere rating or setting of the overcurrent device protecting the ungrounded conductors.
- 2) The size of the bonding conductor installed in accordance with Rule 10-604 at service equipment shall not be less than that determined by the application of Table 16 based on the allowable ampacity of the largest ungrounded conductor. See [Figure 10-2](#) & [10-7](#).

- 3) The size of a field-installed bonding conductor installed at other than service equipment shall not be less than that determined by the application of Table 16 based on:
  - a. the overcurrent device protecting the ungrounded conductors; or
  - b. the allowable ampacity of the largest ungrounded conductor for installations where the size of the circuit conductors is increased to compensate for voltage drop. See [Figure 10-7](#).
- 4) The size of a field-installed bonding conductor installed with each group of parallel conductors run in separate raceways or cables, shall be in accordance with Subrule (3) divided by the number of groups of parallel conductors. See [Figure 10-7](#).
- 5) Notwithstanding Subrules (2), (3) and (4), the bonding conductor shall not be required to be larger than the current-carrying conductors.
- 6) A metal raceway that is permitted to be used as a bonding conductor shall be considered to meet the requirements of this rule.
- 7) A bonding means that is integral to a cable assembly shall be considered to meet the requirements of this rule.

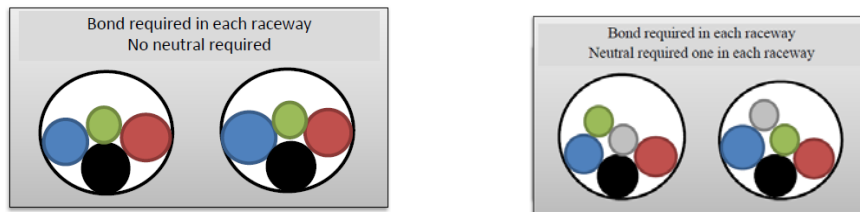

Bonding conductor required in each raceway for parallel conductor installations.

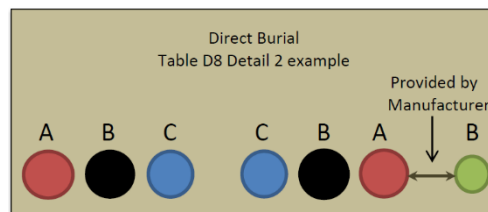

Direct burial parallel conductor installations may require multiple bonds, or a single bond sized to Table 16 and installed **as per manufacturer's instructions**.

[Figure 10-7](#)

## 10-700 - EQUIPOTENTIAL BONDING OF NON-ELECTRICAL EQUIPMENT (SEE APPENDIX B)

The metal parts of structures that livestock access shall be bonded as per 10-616(3) and shall include a connection to a grounding electrode at each location to provide an equipotential plane. This shall include irrigation platforms, irrigation gangways, buildings housing livestock, metal watering bowls, and structures supplied with electricity within the areas accessible to livestock.

**△ Bonding of temporary/portable tents, railings, trusses, and other structures**

Where temporary or portable structures are installed and power cords are in contact with conductive apparatus, the apparatus shall be bonded to ground, or the power circuits shall be Class A type GFCI protected.

**10-700(c) - Replacement of furnaces**

When a furnace or similar piece of equipment is being replaced, the electrical contractor is responsible for bonding the gas line as required by the CEC. The branch circuit cable, providing it has an internal bond conductor as per Rule 10-610 and the low voltage thermostat cable, does not require replacement. See [26-806\(1\)\(5\)\(6\)\(7\)](#). *Caution: Some new furnaces require 20-amp circuits.*

**SECTION 12 – WIRING METHODS**

**12-012 - UNDERGROUND INSTALLATIONS (SEE APPENDIX B)**

**△ 12-012 (12) - Movement due to settlement or frost**

All underground raceways or cables subject to movement require provisions to be made to prevent damage to the conductors or the electrical equipment. The intent of this Rule is to avoid damage to the raceway or cable (during settlement/frost). Attention shall be made to rodent access as well as the movement of the cable in relation to the terminations during the settling or movement due to frost. This may include the use of frost boxes, slip sleeves, cable loop with an expansion joint or other acceptable method.

**△ 12-012(13) - Burial of conductors in proximity to gas lines**

Utility gas lines:

Electrical wiring shall be installed as per the Utility requirements (e.g., SaskEnergy).

“The trench for natural gas must be at least 1 metre (3 feet) from the electrical trench.”

Link to: [SaskEnergy – New Residential Site Readiness](#)

Link to: [SaskEnergy – New Commercial/Industrial Site Readiness](#)

Customer owned gas lines:

Electrical wiring may be installed in the same trench as customer-owned propane or natural gas lines provided the conductors are placed at a greater depth and a separation of at least 300 mm of earth or 150 mm if a treated plank is installed between the piping and conductor.

Customer owned propane or natural gas lines refers to customer lines supplying customer premises.

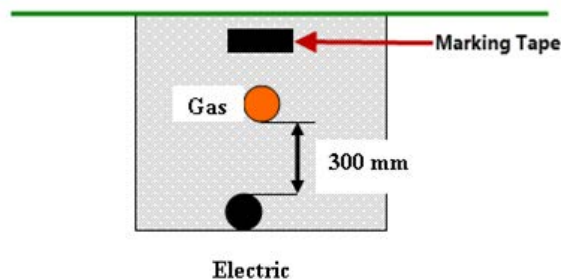

## △ 12-022 - CABLES OR RACEWAYS IN ROOF DECKING SYSTEMS (Q DECKING)

Raceways or cables installed in or on roofing systems using screws or other penetrating fasteners, shall not be installed above the metal roofing pan (Q decking) (#1) and only installed below the roofing pan (Q decking) (#2 & #3) after substantial installation of the roofing has been completed. This does not apply to concrete flooring installations poured over Q decking. See [Figure 12-1](#).

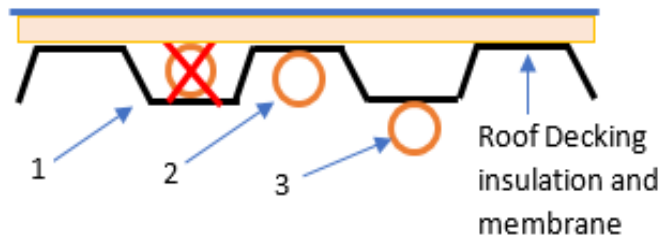

Figure 12-1

## 12-120 - SUPPORTING OF CABLES (SEE APPENDIX B)

12-120(1) – Horizontal – Permanently installed cables and conduits supplying motors, pumps, pressure switches or any other electrical equipment shall be supported as required by Section 12. Cables and conduits where exposed and subject to damage must be supported off the ground by an approved method such as cable tray, strut, etc. Cables must be supported within 300 mm (12”) of any junction box (this includes oil wells). When installing cables, ensure that there is no stress on the connectors from the weight of the cable.

## △ 12-206 - OPEN WIRING RULES

In a renovation where walls are being opened, open wiring shall be replaced. Connections to other systems to refeed existing installations shall be through connections in a junction box and the bonding requirements of Section 10. GFI protection may be required as per Rule 26-702(2).

## △ 12-406(4) - DLO AND FINE-STRAND CABLES PART 2 STANDARDS REQUIREMENTS (SEE APPENDIX B)

C22.2 No. 65 requires that connectors tested for use with conductors more finely stranded than class C indicate the conductor class or classes and the number of strands permitted. This marking may appear on the connector, a unit container, or an information sheet packed with the connector unit pack. DLO cable is an example of a more finely stranded wire than Class C and therefore the connectors must adhere to the marking or labelling requirement for use. See also 12-116.

### △ 12-514 - PROTECTION OF CABLES IN NON-CONCEALED LOCATIONS

Cables run in non-concealed locations, the upper or lower faces of rafters, on the lower faces of ceiling joists, less than 1.5 m above the floor or on the open face of wall studs, shall be protected by installing running boards, guard strips or other means of adequate protection. E.g., 19mm x 38mm (3/4" x 1 1/2") See [Figure 12-2](#).

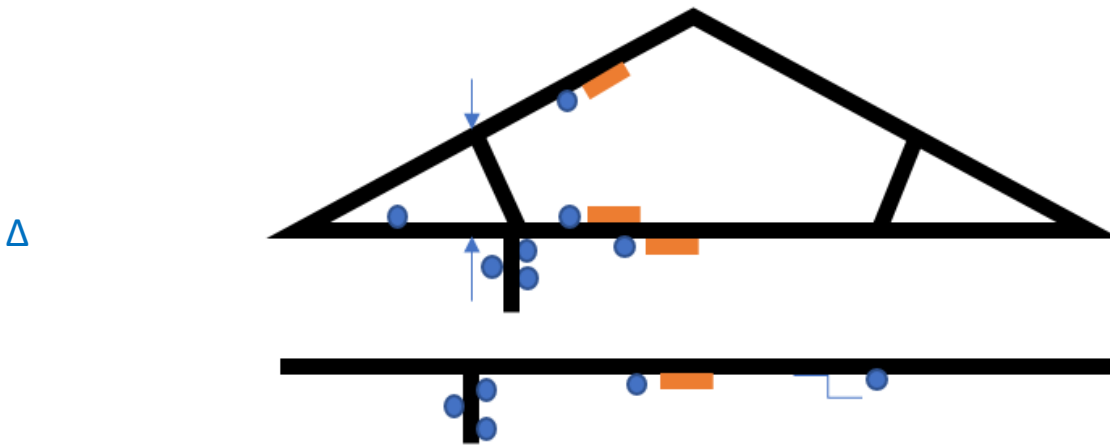

Figure 12-2

### △ 12-608 – CONTINUITY OF ARMoured CABLE (NOTE DELETED)

### 12-610 - TERMINATING ARMoured CABLE (SEE APPENDIX B) (SEE ALSO 2-400)

ACWU or other metallic armoured cables without an inner protective jacket shall incorporate an anti-short or other approved protective device.

### △ 12-910(4) - CONDUCTORS AND CABLES IN CONDUIT AND TUBING (SEE APPENDIX B)

Tables 6A to 6K were revised to provide the area of a single or group of stranded or solid conductors of one size in mm<sup>2</sup>. Table 8 provides the Maximum conduit fill percentage based on the number of conductors. That will take you to the corresponding Table 9 where your conductor area must be equal to or less than the conduit Area in mm<sup>2</sup> value.

Table 10A to 10B are now the first two columns of Tables 6A to 6K. Table 10C information is shown at the bottom of the respective Tables 6A to 6K. 10D remains as these are required for the calculations for DLO cable.

See charts below for common examples of installations using the same conductors in one conduit.

△ 12-910 - TABLES

RW90XLPE 600 volt

Conductor Size	Raceway Type and Size											
	Electrical metallic tubing (EMT)			Rigid metal conduit			Flexible metal conduit			Rigid PVC conduit		
	16 mm	21 mm	27 mm	16 mm	21 mm	27 mm	16 mm	21 mm	27 mm	16 mm	21 mm	27 mm
#14 AWG*	9	16	27	10	18	29	10	17	26	8	15	26
#12 AWG*	7	13	21	8	14	22	7	13	20	6	12	20
#10 AWG*	5	9	16	6	10	17	5	10	15	5	9	15
#8 AWG	2	4	7	2	5	8	2	4	7	1	4	7
#6 AWG	1	3	5	1	3	6	1	3	5	1	3	5

Conductor Size	Raceway Type and Size								
	Metallic liquid-tight flexible conduit			Non-metallic liquid-tight flexible conduit			Electrical non-metallic tubing		
	16 mm	21 mm	27 mm	16 mm	21 mm	27 mm	16 mm	21 mm	27 mm
#14 AWG*	10	17	28	9	16	27	8	15	25
#12 AWG*	7	13	21	7	13	21	6	12	20
#10 AWG*	5	10	16	5	9	15	5	9	15
#8 AWG	2	4	7	2	4	7	1	4	7
#6 AWG	1	3	5	1	3	5	1	3	5

\*Solid conductors

T90 Nylon

Conductor Size	Raceway Type and Size											
	Electrical metallic tubing (EMT)			Rigid metal conduit			Flexible metal conduit			Rigid PVC conduit		
	16 mm	21 mm	27 mm	16 mm	21 mm	27 mm	16 mm	21 mm	27 mm	16 mm	21 mm	27 mm
#14 AWG*	14	25	40	15	26	43	15	25	38	12	23	38
#12 AWG*	10	18	30	11	19	32	11	18	28	9	17	28
#10 AWG*	6	11	18	7	12	20	6	11	17	5	10	17
#8 AWG	3	5	9	3	5	9	3	5	8	2	5	8
#6 AWG	1	4	6	1	4	7	1	4	6	1	3	6

Conductor Size	Raceway Type and Size								
	Metallic liquid-tight flexible conduit			Non-metallic liquid-tight flexible conduit			Electrical non-metallic tubing		
	16 mm	21 mm	27 mm	16 mm	21 mm	27 mm	16 mm	21 mm	27 mm
#14 AWG*	14	25	41	14	24	40	12	23	38
#12 AWG*	11	19	30	10	18	29	9	17	28
#10 AWG*	6	11	19	6	11	18	5	10	17
#8 AWG	3	5	9	3	5	8	2	5	8
#6 AWG	1	4	6	1	4	6	1	3	6

\*Solid conductors



## 12-1118 - EXPANSION JOINTS (SEE APPENDIX B)

PVC conduit shall be installed as per manufacturer's specifications and the CEC. For example, assuming a temperature change of 70 °C, this would mean a minimum of one expansion joint or more may be required depending on the maximum range of the expansion joint. See Rule 12-1012.

### Rules 12-1012, 12-1118, 12-1214 and Appendix B notes

Conduits shall be installed as per manufacturer's specifications and the CEC. The formula to determine if excessive expansion requires mitigation is as follows:

$$E_T = L_R \bullet T_C \bullet C_E$$

Where:

- $E_T$  is the total expansion in mm.
- $L_R$  is the length of the run in meters
- $T_C$  is the temperature change in °C, and
- $C_E$  is the coefficient of linear expansion as per the Table in Appendix B note to Rule 10-1012

#### NOTE:

- The total expansion of the length of the run shall be determined if there are expansion concerns.

#### Example:

For a 20 m run of rigid PVC conduit when the minimum expected temperature is -40°C and the maximum expected temperature is 30°C, the total expansion is:



$E_T = 20 \text{ m} \times (40 + 30) \times 0.0520 = 73 \text{ mm}$ . This exceeds the maximum allowed of 45 mm. Therefore, depending on the travel of the expansion joint, one or more would be required.

## 12-1404 - RESTRICTIONS ON USE - EMT

EMT shall not be used in carwash bay areas due to salt and chemical contaminants. See [22-200\(1\)](#).

## △ 12-1414 - PROVISION FOR BONDING CONTINUITY - EMT

Bonding conductors are required for EMT installations in the following uses:

- (a) concrete or masonry slabs in contact with the earth;
- (b) a wet location; or
- (c) outdoor locations.



## △ SECTION 14 – PROTECTION AND CONTROL

### 14-100(2) - LOADING CABLES (SEE APPENDIX B)

Caution must be taken to prevent overloading of cables which do not have customer protection on the supply side. Example - on a farm service center (F cabinet), where the feeder cable terminates in an exterior splitter for the purpose of supplying more than one service, the total amperage of all main breakers may not exceed the ampacity of the feeder cable.

### 14-104(1) - ADJUSTABLE OVERCURRENT DEVICES (SEE APPENDIX B)

- a) Where the cable ampacity is less than the maximum rating of the adjustable overcurrent (OC) protection devices, the trip settings for the OC protection device shall be documented and on-site for the inspection when available;
- b) The adjustable OC protection devices including fused disconnecting switches, shall be labelled with a lamacoid plate indicating maximum fuse size or amp trip (AT) following the cable ampacity as per Rule 4-004, lamacoid shall read “**Max \_\_\_\_\_ A; Do Not Adjust**”; and
- c) This shall apply to service, feeder and/or branch circuit conductors.

### 14-114 - SUPPLEMENTARY PROTECTION (SEE APPENDIX B)

Electrical Inspectors have encountered supplemental protectors being used as overcurrent devices in industrial control panels and other electrical applications. As a reminder to industry and per Rule 14-114, supplementary overcurrent protection shall not be used as a substitute for branch circuit overcurrent devices or in place of branch circuit protective devices to protect a circuit.

## SECTION 16 – CLASS 1 AND CLASS 2 CIRCUITS

### 16-008 - HAZARDOUS LOCATIONS

Extra low-voltage power circuits installed in hazardous locations on oil field sites (i.e., solar and 12-volt equipment) must be installed in accordance with the applicable rules of Section 18.

## SECTION 18 – HAZARDOUS LOCATIONS

### △ 18-002 - SPECIAL TERMINOLOGY (APPENDIX B)

**EXPLOSION SEAL (ES)** – a seal that:

- When installed at a cable or conduit entry to a flameproof “d”, flameproof “db”, or explosion-proof enclosure, prevents the ignition of an explosive gas atmosphere outside the enclosure;
- When installed in a conduit, prevents the passage of an explosion from one portion of the conduit system to another; and
- Minimizes the passage of flammable fluids at atmospheric pressure.





**FLAMMABLE FLUID MIGRATION SEAL (FM)** – (Boundary Seal) – a cable or conduit seal (sealing compound such as duct seal, silicone...) intended to minimize the transmission of flammable fluids and gases when located at or near atmospheric pressure. Must be permanently marked to indicate ‘fluid migration seal’ at the fitting.

## 18-004 - CLASSIFICATION OF HAZARDOUS LOCATIONS (SEE APPENDICES B, J, AND L)

Hazardous area classification or reclassification as per CEC Appendix L shall be carried out and documented by qualified persons and shall be authenticated by the person assuming responsibility (Professional Engineer).

Installations as described within the scope of Sections 18, 19, 20 & 22 shall be the minimum permissible classification unless reclassified by a Professional Engineer.

Area classifications or reclassifications complete with an assessment report and stamped drawings shall be provided to the Electrical Inspections department.

For selection of equipment refer to Table 18.

### Micro-breweries and alcohol distilleries

Micro-breweries and alcohol distilleries contain several hazardous locations. Plans and hazardous location classifications shall be provided to the Electrical Inspections department prior to construction.

## 18-006 - AMMONIA COMPRESSOR ROOMS (SEE APPENDICES B AND L)

When ammonia is used in a refrigerant system, the room shall be considered a Zone 2 hazardous location unless the room is constructed to a **Class T machinery room** as specified in the *CSA standard B52-95 Mechanical Refrigeration Code*.

## △ 18-008 - LOCATIONS CONTAINING AN EXPLOSIVE DUST ATMOSPHERE (SEE APPENDICES B AND L)

All grain handling systems are classified Zone 20 locations. The bag handling areas are a Zone 22 location when suitably cutoff from the main handling area. The location may be reclassified as per Rule 18-004. See App E for dust free room requirements.

### Bio diesel and canola crushing plants

As per Rule 18-008 of the CEC, canola crushing is a Zone 20 location, and all wiring must meet the minimum CEC requirements for the installation. Canola storage and product transferring would fall under the same area classification.

In the process of creating bio diesel, an additive must be added. If that product is methanol or another volatile additive, a hazard arises. The process must be classified or reclassified as per Rule 18-004. Storage of methanol is under the same area classification. Bio diesel storage is the same as regular diesel and must also meet all other provincial codes and rules.



# 18-008 - HAZARDOUS AREA CLASSIFICATION - GRAIN ELEVATOR

Zone 20 

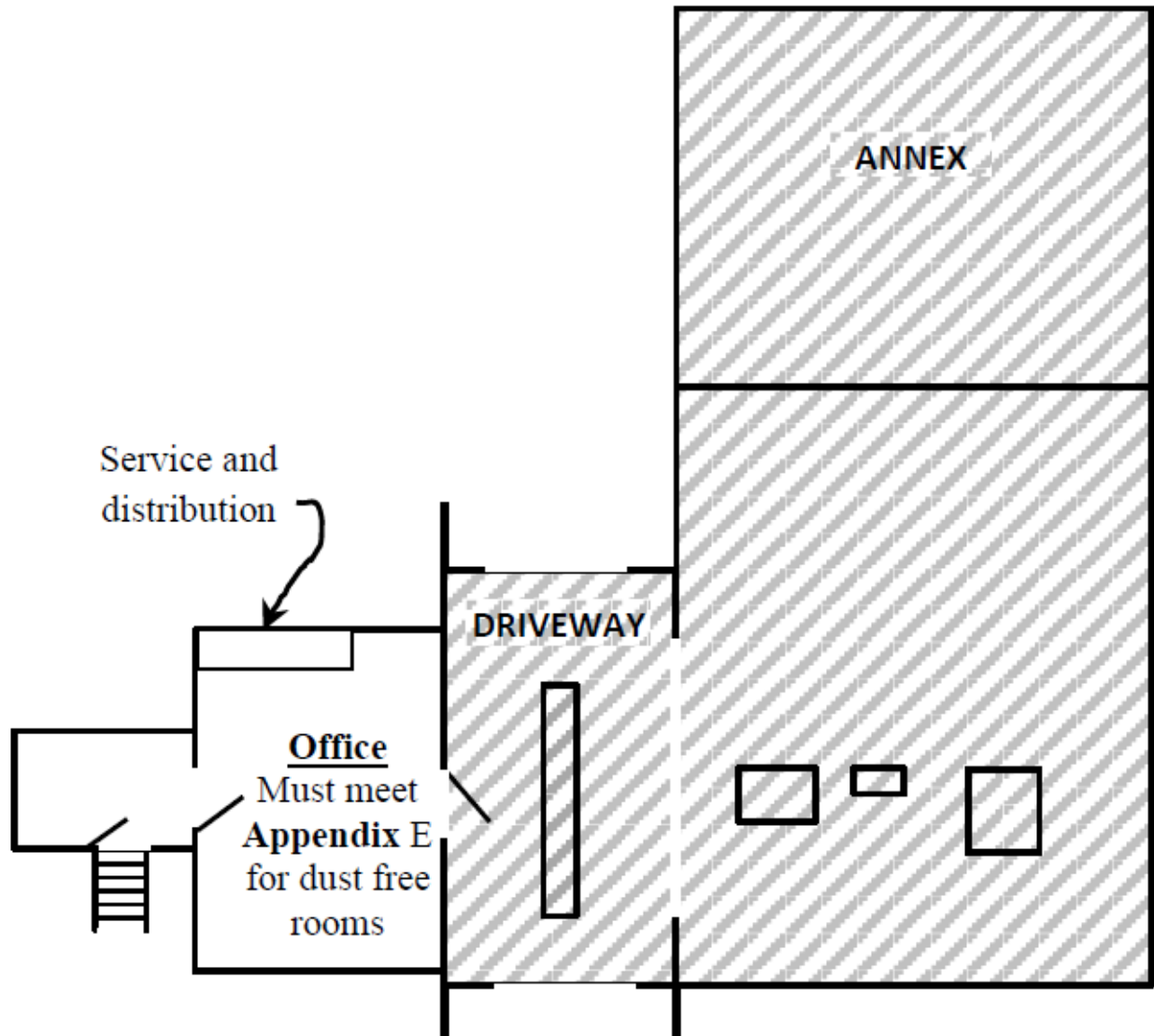

Figure 18-1



## 18-008 - HAZARDOUS AREA CLASSIFICATION - SEED CLEANING PLANT

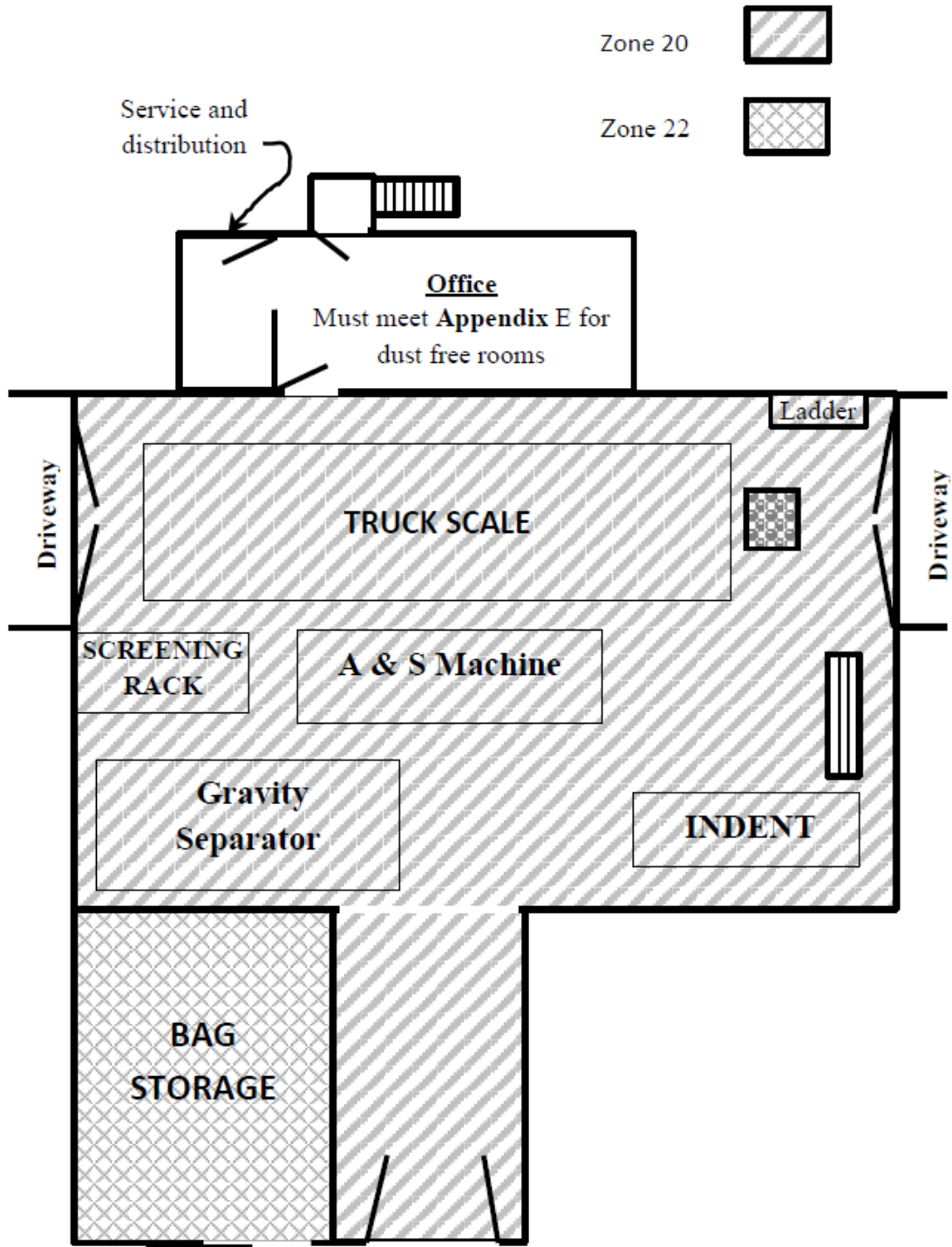

Figure 18-2

## 18-008 - HAZARDOUS AREA CLASSIFICATION - FEED MILL FLOOR PLAN

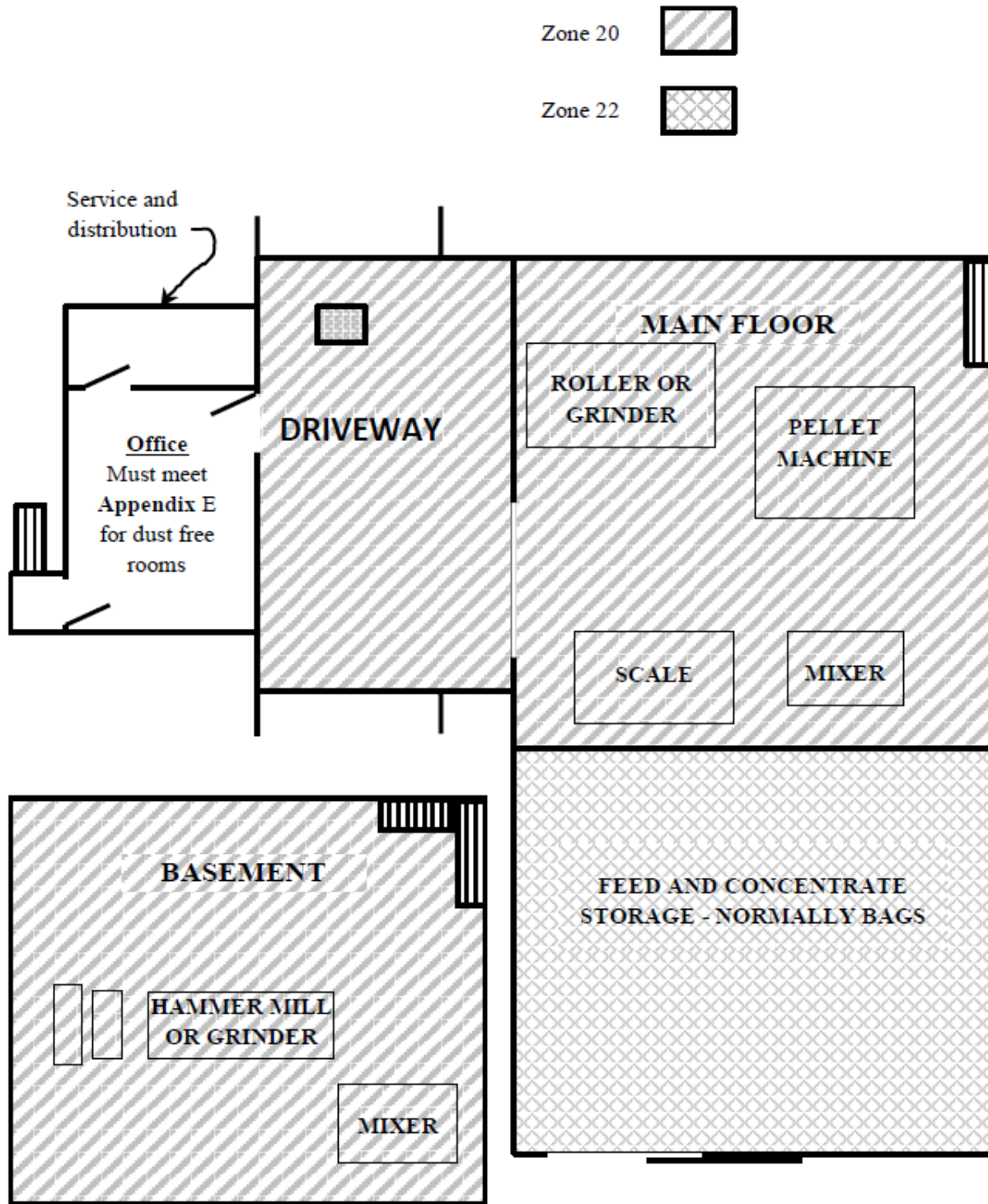

Figure 18-3

## Woodworking plants and sawmills

The CEC classifies these areas as Zone 22 locations without adequate dust collection. Areas may be reclassified by a Professional Engineer. For the purposes of this rule, non-commercial residential garages and shops may not be considered wood working plants.

The following will be permitted where good housekeeping habits and adequate dust collection equipment is installed:

- a) Panelboards, controllers, etc. shall be dust tight or in dust tight enclosures.
- b) Wall surface wiring shall be threaded rigid, EMT (with rain-tight connectors) or TECK cable with dust-tight TECK connectors.
- c) Ceiling surface wiring may be ordinary location wiring methods.
- d) Boxes shall comply with Rule 18-252(2).
- e) Concealed wiring may be type AC or NM cable.
- f) Concealed boxes and fittings may be ordinary type.
- g) Switch and receptacle covers shall be of the weatherproof type.
- h) Where duplex receptacles are used, a separate self-closing cover will be required for each section of the receptacle.
- i) General purpose fluorescent lighting fixtures may be installed:
  - i. if mounted directly on the ceiling; or
  - ii. if suspended and provided with adequate dust shields to prevent the accumulation of dust.

## 18-050 - ELECTRICAL EQUIPMENT (SEE APPENDICES B, AND J)

Selection of equipment for hazardous locations shall be in accordance with Table 18.

## 18-052 - MARKING OF EQUIPMENT

CSA has adopted the IEC standard for equipment protection levels (**EPL's**) as a requirement for marking on equipment in hazardous locations. This marking system will now appear on new hazardous location equipment. See **CEC Table 18** for more information.

## Δ 18-066 - INTRINSICALLY SAFE AND NON-INCENDIVE ELECTRICAL EQUIPMENT AND WIRING (SEE APPENDIX B)

Where an intrinsically safe electrical system or non-incendive field wiring circuit is installed in a hazardous location, a descriptive systems document shall be available on site to the Electrical Inspector and the systems shall be installed and maintained in accordance with this document.

## 18-070 - COMBUSTIBLE GAS DETECTION (SEE APPENDICES B AND H)

The intent of this Rule is **not** to declassify an area; it is only to be used where suitable equipment approved for the area is **not available** with proper classification for a hazardous area.

- E.G., - General equipment to be installed in a Zone 2 location  
- Zone 2 equipment to be installed in a Zone 1 location

## △ 18-104, 18-154 - SEALING ZONE 1 & 2

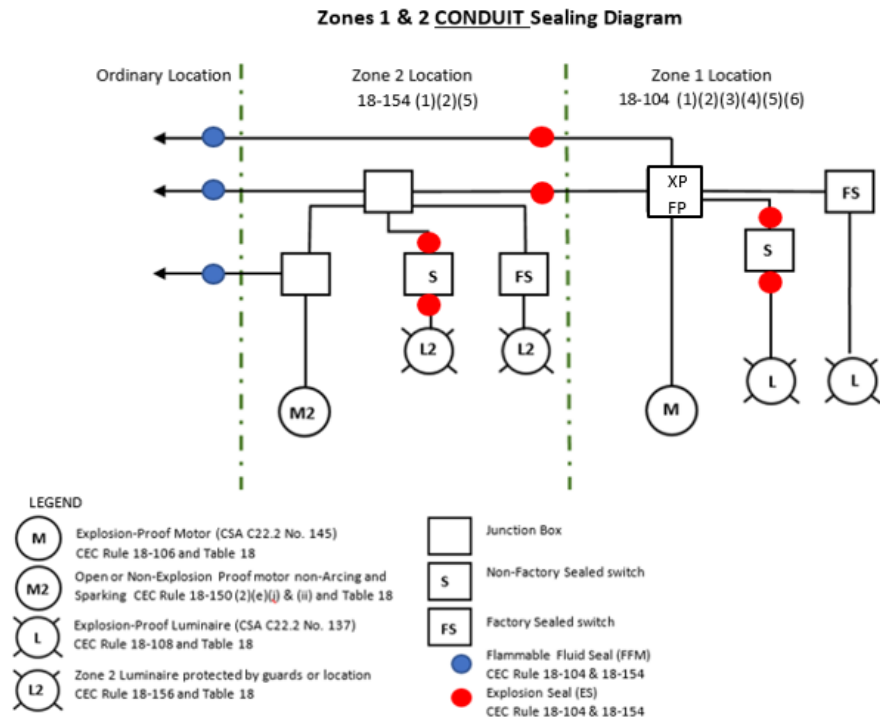

Figure 18-4

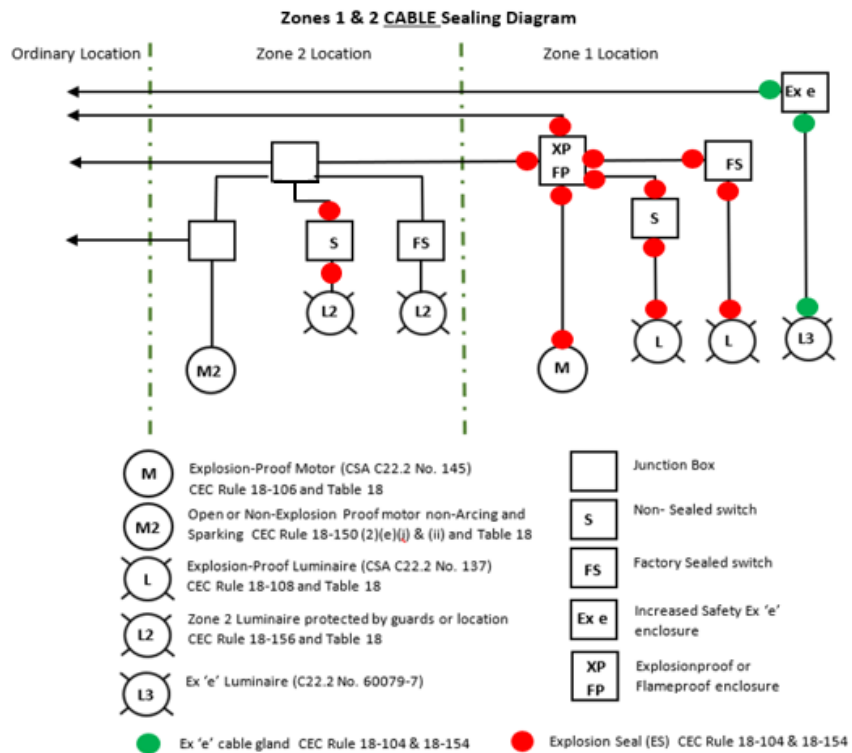

Figure 18-5



### **Flammable Fluid Migration Seals**

18-104(7) – A cable entering or leaving a Zone 1 location must be sealed with a ‘flammable fluid migration seal’ where it first terminates in the hazardous location regardless of the type of box it enters. See [Figure 18-5](#)

18-154(2) – A conduit entering or leaving a Zone 2 location must be sealed with a ‘flammable fluid migration seal’ where it first enters or leaves the hazardous location with no box, coupling or fitting between the seal and the point at which the conduit leaves the area. See [Figure 18-4](#)

### **18-152 & 18-252 - WIRING METHODS, ZONE 2 & ZONE 22**

Liquid tight metal flexible conduit shall be marked for Heavy Duty.

### **18-250 - EQUIPMENT, ZONE 22 LOCATIONS**

 TEAO fan motors mounted in the air flow and TEFC motors that meet the requirements of Table 18 and do not in normal service have ignition-capable hot surfaces or produce incendive arcs or sparks will be permitted in Zone 22 locations and grain handling facilities re-classified as Zone 22.

**NOTE:** Internal thermistor leads should be connected.

**SECTION 20 – FLAMMABLE LIQUID AND GAS DISPENSING AND SERVICE STATIONS, GARAGES, BULK STORAGE PLANTS, FINISHING PROCESSES AND AIRCRAFT HANGARS**

**20-004 - ISLAND GAS PUMP**

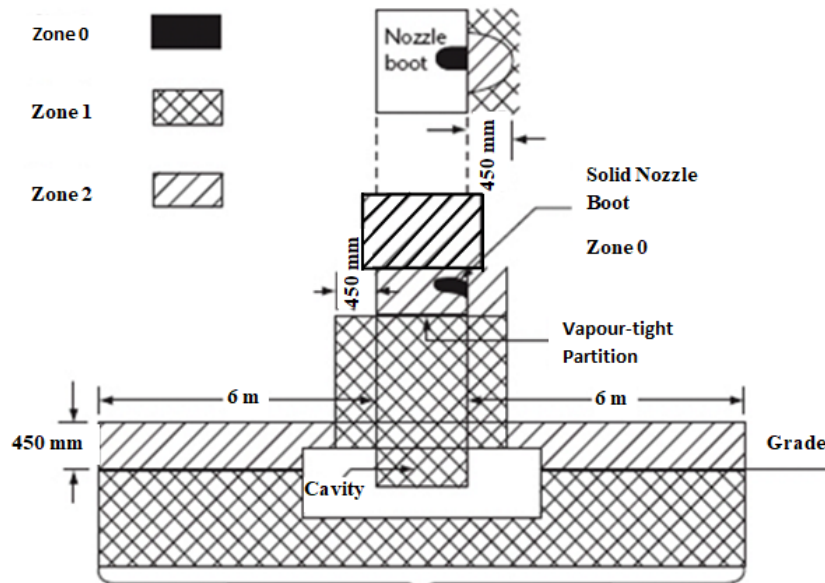

Any conduits leaving the hazardous area where the electrical wiring emerge from the ground shall meet the sealing requirements of Section 18 and 20

Figure 20-1

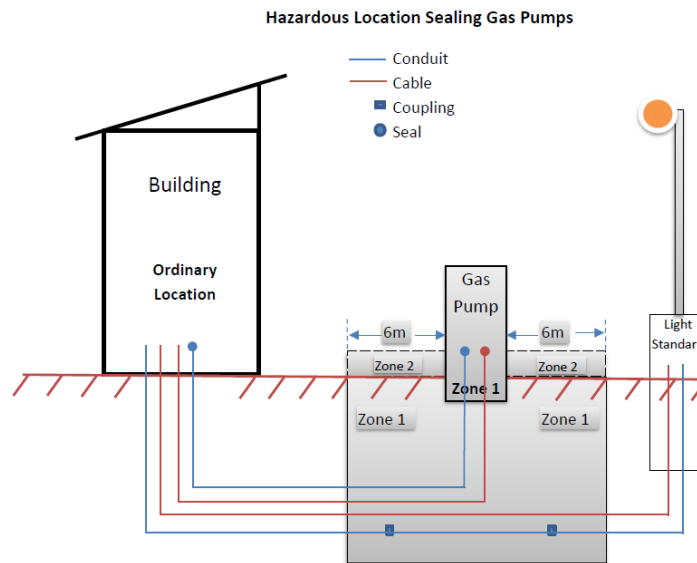

Figure 20-2

Cables and conduits that run through the Zone 1 area need to meet the wiring methods and sealing requirements of Section 18 whether they are associated with the pump or not.





## 20-102(1) - HAZARDOUS AREA COMMERCIAL REPAIR GARAGES

All adjacent rooms not suitably cut off with a 50 mm (2") barrier are classified as hazardous up to 50 mm (2") above the parking floor.

## 20-102(2) & (3) - CLARIFICATION OF PITS OR DEPRESSIONS BELOW FLOOR LEVEL

For the purpose of Rule 20-102(2), a floor below grade is defined as - any area where daily work and storage of product takes place (i.e., vehicle service area, storage areas, etc.).

For the purpose of Rule 20-102(3), a pit is defined as - any area below grade where every day work does not take place (i.e., sump pit, etc.).

## Δ 20-200 - ANHYDROUS AMMONIA

Anhydrous ammonia is considered to be a volatile liquid which is flammable in a gaseous state and, as such, shall be wired in accordance with Rules 20-202 to 20-212, regardless of the aggregate capacity of the tank.

## 20-300 - FINISHING PROCESSES

We are starting to see the use of "water-base" or "waterborne" paints in automotive and other finishing processes. While the base coat may be "water-base" or "waterborne" other components of the paint are flammable and therefore Section 20 still applies, unless it can be proven with the MSDS sheets that there are no flammable components involved.

Applies to areas where:

- paints, lacquers or other flammable finishes and fiberglass processes are regularly or frequently applied by spraying, dipping, brushing or by other means;
- volatile flammable solvents or thinners are used; or
- readily ignitable deposits or residues from such paints, lacquers or finishes may occur.

## 20-302 - PAINT MIXING ROOMS

All paint mixing rooms are classified Zone 1 locations unless it can be proven that all the products involved are non-flammable.

## SECTION 22 – LOCATIONS IN WHICH CORROSIVE LIQUIDS, VAPOURS OR EXCESSIVE MOISTURE ARE LIKELY TO BE PRESENT

### 22-002 - CATEGORIES (APPENDIX B)

- △ Greenhouses, grow-ops, and freezers - are considered a Category 1 location. EMT with wet location fittings will be permitted. The area classification may be reduced to a standard location if ventilation and humidity controls are present. See Rule [12-1414](#) provisions for bonding using EMT for Category 1 locations. All walk-in coolers are standard locations.

### 22-108 -WIRING DEVICES AND CONNECTORS

- △ Enclosures, receptacles, inlets, attachment plugs and covers installed in a Category 1 or Category 2 location, shall be constructed for the Category, protected whether a plug is inserted or not (In-Use covers), selected in accordance with engineering / manufactures specifications or table 65 and may also require ingress protection.

Receptacles shall be weather resistant (WR) rated for Category 1 or corrosion resistance (yellow) rated for Category 2.

### 22-200(1) - WIRING METHODS IN CATEGORY 1 LOCATIONS

Car wash - Car washes are classified as Category 1 locations. All wiring methods and equipment must be approved for wet locations. EMT shall not be used in car wash bay areas due to salt and chemical contaminants. See [12-1404](#).

### 22-202 - WIRING METHODS IN CATEGORY 2 LOCATIONS

Granular fertilizer storage - All electrical equipment installed for bulk granular fertilizer storage buildings, bins, load and unload equipment, distribution chutes and augers and surrounding exterior areas, subject to corrosion under normal operation of the equipment from a combination of the fertilizer dust and humidity/moisture, must be approved for the location in accordance with Rule 2-116. Non-essential equipment shall not be installed in handling or processing areas.

Raceways may be PVC, or other non-corrosive material, with fittings and enclosure entries of such design as to not constitute dissimilar metals in contact with each other, and to exclude dust. TECK 90 cable with non-corrosive fittings shall be permitted to be installed at bulk fertilizer storage structures.

Equipotential grounding and bonding conductors shall be of copper or equivalent and insulated where exposed to corrosion. Any terminations shall be protected from corrosion by an approved sealant or epoxy paint.

## SEWAGE LIFT AND TREATMENT PLANTS

### 22-704 - CLASSIFICATION OF AREAS

#### Sewage Lift & Handling

<b>The following chart shows the classification of various locations in sewage lift and treatment plants</b>		
<b>Location</b>	<b>Condition</b>	<b>Classification</b>
Wet Wells	With adequate continuous positive pressure ventilation	Zone 2, Category 2
All below-ground dry-well location	Suitably cut off from sewage gas location	Category 1
All locations	Sewage gas is present in explosive concentrations	Zone 1, Category 2
All locations	Suitably cut off from a Category 2 location and not classified as a Category 1 location.	Ordinary location
All locations	Not suitably cut off from a Category 2 location but with adequate continuous positive pressure ventilation.	Ordinary location
Below-ground dry well locations	With adequate heating and adequate continuous positive pressure ventilation	Ordinary location

Typical Sewage Lift Station (self-contained) [Figure 22-1](#)

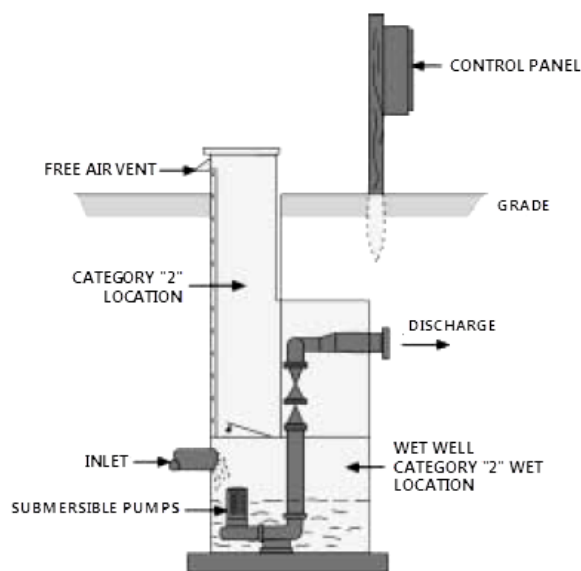

Building - Ordinary Location [Figure 22-2](#)

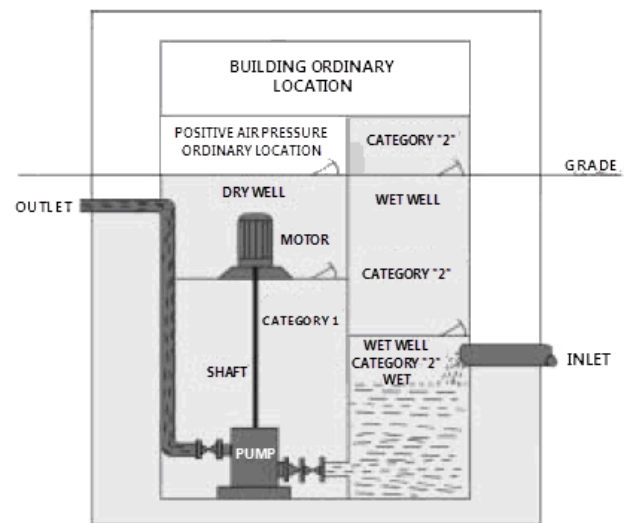

## △ 22-804 - CLASSIFICATION OF AREAS

Wiring in buildings housing livestock, as defined in 22-802, shall be for Category 1 and Category 2 locations. Areas suitably cut-off may be considered dry locations.

## △ 22-806 - ELECTRICAL EQUIPMENT, LUMINAIRES, AND RECEPTACLES (SEE APPENDIX B)

Other than electrical equipment exempted under subrule (1), all receptacles must be weather resistant (WR) and/or corrosion resistant (Yellow), and luminaires and other equipment type in accordance with 22-102 & 22-104.

## △ 22-808 - WIRING METHODS (SEE APPENDIX B)

The wiring methods shall be of the type listed in Table 19.

- PVC conduit along with PVC boxes, straps and approved expansion joints as required. Wire within the conduit must be approved for a wet location or damp location if the barn is equipped with adequate humidity control;
- TECK 90 cable along with approved connectors, non-corrosive boxes, and straps; or
- Non-metallic sheath cable except in any location where it may be susceptible to damage by rodents; and
- Wiring for watering bowls may be of aluminum. Terminations shall be protected with an antioxidant and effectively sealed.

### NOTES:

- All screws used for the mounting of equipment, raceways etc. must be corrosion resistant.
  - Non-metallic sheath cable cannot be run inside the walls, ceiling/attics or any other concealed space in a barn, office, tack room or similar area attached to or within the barn unless provided with mechanical protection.
  - When non-metallic sheath cable passes through a location where it may be exposed to rodents, it must be provided with mechanical protection in the form of rigid steel, rigid non-metallic conduit, or other suitable material when:
    - Installed in exposed locations within 300 mm (12") above any horizontal surface; or
    - Installed in exposed locations on the sides of floor joists or other structural members less than 100 mm (4") below the upper surface.
  - Aluminum conductors and AC90 (BX, ACWU) cables are not approved for use in buildings housing livestock.
- △
- Non-metallic sheathed cable is not approved for installation in a continuous raceway system.
  - When an office, tack room, riding arena, sales arena or similar room is attached or within the barn, the wiring methods shall be the same as the rest of the building. If the office, tack room, etc. is suitably cutoff from the barn by vapour tight walls, ceiling, floor, a sealed door and sealed raceways, normal equipment and wiring methods (i.e., panelboards, lighting, etc.) may be installed in the interior of this room (surface mounted, not recessed within the ceiling or walls).

## SECTION 24 – PATIENT CARE AREAS

### DEFINITIONS - HEALTH CARE FACILITIES

#### Health care facility - Class A

A hospital so designated by Canada or one of its Provinces or Territories, where patients are accommodated based on medical need and are provided with continuing medical care and supporting diagnostic and therapeutic services.

**NOTE:** Class A Facilities include acute and complex care.

#### Health care facility - Class B

A facility where residents, as a result of physical or mental disabilities, are unable to function independently and are accommodated due to a need for daily care by health care professionals.

**NOTE:** Class B Facilities provide extended, multi-level, hospice, psychiatric or intermediate care. The definition includes rehabilitation facilities.

#### Health care facility - Class C

A facility where ambulatory patients are accommodated based on medical need and are provided with supportive, diagnostic and treatment services.

**NOTE:** Class C Facilities include outpatient and surgical clinics, dental offices, doctors' clinics, private residences, and group homes.

### 24-000 - CLASSIFICATION OF AREAS

Contractors need to be aware of the determination of patient care areas and provide this information to the Electrical Inspector prior to commencing work. Plans shall be submitted with indication of different patient care levels (basic, intermediate, or critical), patient care environments and branch circuit wiring details.

A rough-in inspection shall be booked prior to closing in of walls. See [2-012](#).

Patient care areas are defined by the CAN/CSA-Z32 standard and include, but are not limited to, walk-in medical clinics, dental clinics, chiropractic clinics, massage/physiotherapy, optometrists, and others. This means that the specific rooms of a clinic in which treatment is given may be required to be wired in accordance with Section 24 methods.

**The health region, clinic or hospital administrators are the personnel who will determine the area use for their facilities.**

## 24-106(7) - RECEPTACLES IN BASIC CARE AREAS

Isolated ground receptacles shall not be used in any patient care area.

## 24-110 - CIRCUITS IN INTERMEDIATE AND CRITICAL CARE AREAS

The requirement of 2-wire circuits (e.g., dedicated grounded circuit conductors/neutral) applies to the patient care environments within intermediate and critical care areas.

### CAN/CSA-Z32-Patient Care Environment

A zone in a patient care area that has been preselected for the accommodation of a patient bed, table, or other supporting mechanism, and for the accommodation of equipment involved in patient treatment and which includes space within the room 1.5 meters beyond the perimeter of the bed in its normal location and to within 2.3 meters of the floor. The patient environment is a zone fixed to the supporting mechanism and does not move with the patient as the patient moves through the health care facilities.

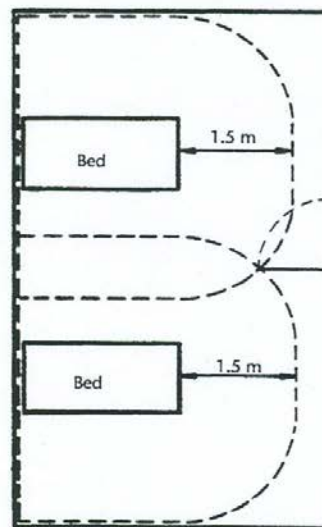
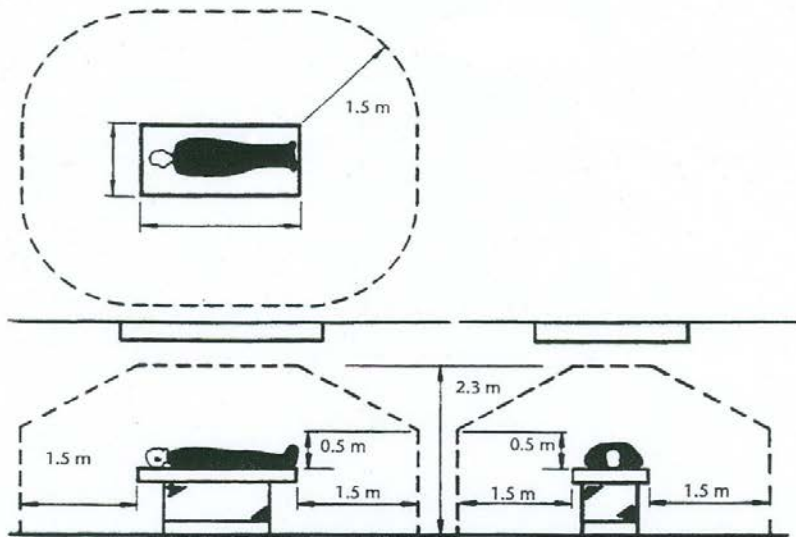

**Patient Care Environment**

## SECTION 26 – INSTALLATION OF ELECTRICAL EQUIPMENT

### Single phase transformer full load current in amperes

kVA	120v	240v	480v	600v	2400v	4160v	14400v
2	16.7	8.3	4.2	3.3	0.83	0.48	0.14
3	25	12.5	6.3	5.0	1.25	0.73	0.21
5	41.7	20.8	10.4	8.3	2.08	1.2	0.35
7.5	62.5	31.3	15.6	12.5	3.13	1.8	0.52
10	83.3	41.7	20.8	16.7	4.17	2.4	0.69
15	125	62.5	31.3	25.0	6.25	3.6	1.04
20	167	83.3	41.7	33.3	8.33	4.8	1.39
25	208	104	52.1	41.7	10.4	6.0	1.74
30	250	125	62.5	50.0	12.5	7.2	2.08
37.5	313	156	78.0	62.5	15.6	9.0	2.61
50	417	208	104	83.3	20.8	12	3.47
75	625	313	156	125	31.3	18	5.21
100	833	417	208	167	41.7	24	6.94
167	1391	695	347	278	69.6	40.1	11.6
200	1667	833	417	333	83.3	48.1	13.9
250	2083	1041	520	416	104	60.1	17.4
333	2115	1387	693	555	138	80	23.1
500	4167	2083	1042	833	208	120	34.7
750	6250	3125	1563	1250	313	180	52.1
1000	8333	4167	2083	1667	417	240	69.4

$$\text{KVA} = \text{Voltage (Current)} / 1000$$

### Three phase transformer full load current in amperes

kVA	208v	240v	480v	600v	2400v	4160v	13800v	14400v
3	8.3	7.2	3.6	2.9	0.72	0.42	0.126	0.120
6	16.6	14.4	7.2	5.8	1.46	0.82	0.251	0.241
9	25	21.7	10.8	8.7	2.17	1.25	0.377	0.361
15	41.7	36.1	18.2	14.5	3.61	2.09	0.628	0.601
30	83.4	72.3	36.1	28.9	7.23	4.17	1.26	1.202
45	125	108	54.2	43.4	10.8	6.26	1.88	1.805
50	139	120	60.2	48.2	12	6.96	2.09	2
75	208	181	90.3	72.3	18.1	10.4	3.14	3.005
112.5	313	271	135	108	27.1	15.7	4.71	4.51
150	417	361	181	145	36.1	20.9	6.28	60.1
200	556	482	241	193	48.2	27.8	8.37	8.02
225	625	542	271	217	54.2	31.3	9.41	9.025
300	834	723	361	289	72.3	41.7	12.55	12.02
450	1249	1083	541	433	108	62.5	18.83	18.04
500	1390	1204	602	482	120	69.6	20.92	20.07
750	2082	1804	902	722	180	104	31.38	30.07
1000	2776	2406	1203	962	241	139	41.84	40.09
1500	4164	3608	1804	1443	361	208	62.76	60.14
2000	5552	4811	2406	1925	481	278	83.67	80.19

$$\text{KVA} = 1.73 (\text{Voltage}) (\text{Current}) / 1000$$

26-254 & 26-256 - 3 phase dry-core transformer tables



## 26-254 & 26-256: 3 phase dry-core transformer tables

Based on 125% of the primary rated current (FLA)

Without Secondary Protection

Step-down transformers with primary overcurrent only

3 Phase Dry-type Transformers rated 750 V or less-Rule 26-254 & 26-256											
KVA	600 Volt primary							480 Volt secondary			
	FLA	125% of FLA	75 ° * Cond.	#1 Max. O/C		Equip. Rating		FLA	125% of FLA	75 ° * Cond.	#2 System Bond Jumper
				Breaker Size	Fuse Size	Breaker	Fuse				
4.5	4.33526	5.41908	14	15	5	30	30	5.41908	6.77384	14	14
9	8.67052	10.8382	14	15	10	30	30	10.8382	13.5477	14	14
15	14.4509	18.0636	14	15	15	30	30	18.0636	22.5795	12	14
22.5	21.6763	27.0954	10	25	25	30	30	27.0954	33.8692	10	10
30	28.9017	36.1272	8	35	35	60	60	36.1272	45.159	8	10
45	43.3526	54.1908	6	50	50	60	60	54.1908	67.7384	4	8
75	72.2543	90.3179	3	90	90	100	100	90.3179	112.897	2	6
100	96.3391	120.424	1	100	110	100	200	120.424	150.53	2/0	6
112.5	108.382	135.477	1/0	125	125	200	200	135.477	169.346	2/0	6
150	144.509	180.636	3/0	175	175	200	200	180.636	225.795	4/0	6
200	192.678	240.848	250	225	225	400	400	240.848	301.06	350	4
225	216.763	270.954	300	250	250	400	400	270.954	338.692	500	3
300	289.017	361.272	500	350	350	400	400	361.272	451.59	2 x 4/0	2

3 Phase Dry-type Transformers rated 750 V or less-Rule 26-254 & 26-256											
KVA	600 Volt primary							208 Volt secondary			
	FLA	125% of FLA	75 ° * Cond.	#1 Max. O/C		Equip. Rating		FLA	125% of FLA	75 ° * Cond.	#2 System Bond Jumper
				Breaker Size	Fuse Size	Breaker	Fuse				
4.5	4.33526	5.41908	14	15	5	30	30	12.5056	15.6319	14	14
9	8.67052	10.8382	14	15	10	30	30	25.0111	31.2639	10	10
15	14.4509	18.0636	14	15	15	30	30	41.6852	52.1065	6	10
22.5	21.6763	27.0954	10	25	25	30	30	62.5278	78.1597	4	8
30	28.9017	36.1272	8	35	35	60	60	83.3704	104.213	2	6
45	43.3526	54.1908	6	50	50	60	60	125.056	156.319	2/0	6
75	72.2543	90.3179	3	90	90	100	100	208.426	260.532	300	4
100	96.3391	120.424	1	100	100	100	200	277.901	347.377	500	4
112.5	108.382	135.477	1/0	125	125	200	200	312.639	390.799	600	3
150	144.509	180.636	3/0	175	175	200	200	416.852	521.065	2 x 300	2
200	192.678	240.848	250	225	225	400	400	555.803	694.753	2 x 500	1/0
225	216.763	270.954	300	250	250	400	400	625.278	781.597	2 x 600	1/0
300	289.017	361.272	500	350	350	400	400	833.704	1042.13	4 x 300	3/0

**Turns Ratio**  
 600 / 480 = 1.25  
 480 / 208 = 2.30  
 600 / 208 = 2.88

$$\text{Amperes} = (\text{KVA} \times 1000) / (\text{Volts} \times \sqrt{3})$$

**Volts x √3**  
 600 x 1.732051 = 1039.23  
 480 x 1.732051 = 831.38  
 208 x 1.732051 = 360.27





Based on 125% of the primary rated current (FLA)  
Without Secondary Protection

Step-down transformers with primary overcurrent only

3 Phase Dry-type Transformers rated 750 V or less-Rule 26-254 & 26-256											
KVA	480 Volt primary							208 Volt secondary			
	FLA	125% of FLA	75° * Cond.	#1 Max. O/C		Equip. Rating		FLA	125% of FLA	75° * Cond.	#2 System Bond Jumper
				Breaker Size	Fuse Size	Breaker	Fuse				
4.5	5.41908	6.77384	14	15	6	30	30	12.5056	15.6319	14	14
9	10.8382	13.5477	14	15	13	30	30	25.0111	31.2639	10	10
15	18.0636	22.5795	12	20	20	30	30	41.6852	52.1065	6	10
22.5	27.0954	33.8692	10	30	30	30	30	62.5278	78.1597	4	8
30	36.1272	45.159	8	40	40	60	60	83.3704	104.09	2	8
45	54.1908	67.7384	4	60	60	60	60	125.056	156.319	2/0	6
75	90.3179	112.897	2	100	100	100	200	208.426	260.532	300	4
100	120.424	150.53	2/0	150	150	200	200	277.901	347.377	500	3
112.5	135.477	169.346	2/0	150	150	200	200	312.639	390.799	600	3
150	180.636	225.795	4/0	225	225	400	400	416.852	521.065	2 x 300	1
200	240.848	301.06	350	300	300	400	400	555.803	694.753	2 x 500	1/0
225	270.954	338.692	500	300	300	400	400	625.278	781.597	2 x 600	1/0
300	361.272	451.59	2 x 4/0	400	400	400	600	833.704	1042.13	4 x 300	2/0

note #1: O/C protection sized not to exceed 125% of the transformer primary FLA.

#2: The system bonding jumper shall be sized as per Rule 10-614(3)(a)&(5) (Table 16). See App "B" Based on Table 16, Col. 1 using primary O/C size multiplied by the turns ratio.

\*: All conductors are copper.

Example:

30 Kva, 600 volt to 120/208 delta/gye transformer.

Primary

$$(30 \text{ Kva} \times 1000) / (600 \times \sqrt{3})$$

$$30000 / 1039.23$$

$$28.87 \text{ amps}$$

$$28.87 \text{ amps} \times 125\%$$

$$36.09 \text{ amps}$$

Secondary:

$$(30 \text{ Kva} \times 1000) / (208 \times \sqrt{3})$$

$$30000 / 360.27$$

$$83.27 \text{ amps}$$

$$83.27 \text{ amps} \times 125\%$$

$$104.09 \text{ amps}$$

This can be installed with a minimum #10 awg conductor on a 35 amp breaker (60 amp equipment) or 35 amp fuse (60 amp equipment) without secondary overcurrent protection because when multiplied by the turns ratio the amperage is not in excess of the secondary value.

Example:

35 amp (for breaker) x 2.88 = 100.8 amps or 35 amp (for fuse) x 2.88 = 100.8 amps.  
This value does not exceed the calculated ampacity of 104.09 amps for the secondary.  
The value of the secondary overcurrent does not exceed 104.09 amps so therefore secondary overcurrent protection is not required.

If the primary overcurrent (FLA x 125%=36.127 amps) is adjusted to the next common size as allowed by 26-256(3) then a 40 amp breaker (60 amp equipment) or a 40 amp fuse (60 amp equipment) could be used but secondary overcurrent protection would be required because when multiplied by the turns ratio the amperage is in excess of the secondary value.

Example:

40 amp (for breaker) x 2.88 = 115.2 amps or 40 amp (for fuse) x 2.88 = 115.2 amps.  
This value exceeds the calculated ampacity of 104.09 amps for the secondary.  
The value of the secondary overcurrent does exceed 104.09 amps so therefore secondary overcurrent protection rated at 104.09 amps or less is required.



## 26-256 - LIMITING CURRENT OUTPUT (CHOKING) OF A DRY-TYPE TRANSFORMER

If the secondary conductors or equipment connected to the secondary of the transformer are less than 1.25 x the transformer's rated secondary current, but equal to or greater than the primary overcurrent (OC) multiplied by the transformers turns ratio, secondary OC protection is not required.

**The primary OC device shall be labelled to indicate the maximum rating of the OC protection.**

## 26-600 - LOCATION OF PANELBOARDS (SEE APPENDIX G)

In a retrofit where an existing service is upgraded at the same location, the new panelboard need not be lowered. If the location is otherwise undesirable, reference [6-206\(1\)\(c\)](#), the new panelboard shall be made to comply with the current CEC.

Panelboards shall not be enclosed in thermally insulated walls.

In all new installations in dwelling units, with the exception of the main breaker or disconnect switch, no branch circuit overcurrent device shall be located at a height greater than 1.7 m above the finished floor.

## △ 26-656 - BRANCH CIRCUITS FOR SINGLE DWELLINGS

At least one dedicated separate circuit is required for all outdoor receptacles. More than one dedicated circuit may be installed for outdoor receptacles, but there shall be no interconnection of indoor and outdoor receptacles. This does not include the receptacles on a balcony of apartment buildings.

Smoke detectors and CO detectors installed during the sub-division of a dwelling unit should, where possible, be fed from a lighting circuit in a common area.

## 26-658 - ARC FAULT PROTECTION OF BRANCH CIRCUITS FOR DWELLING UNITS (SEE APPENDIX B)

Combination arc fault protection as defined in Rule 26-658 is required for all branch circuits in new construction or renovations/additions of dwelling units except for:

- Bathroom receptacles within 1 M (39") of the wash basin;
- Refrigerator receptacles (includes a separate circuit labeled as fridge or freezer in another location i.e., basement, garage, etc.);
- Kitchen counter receptacles;
- Island receptacles;
- Peninsula receptacles;
- A single receptacle for a sump pump, septic pump, central heating and/or related equipment that does not supply any other receptacles; or
- A dedicated receptacle on a separate circuit wired as per Section 24 for home dialysis equipment, as an example, will require the receptacle to be clearly labelled as to its purpose.

## NOTES:

- A dwelling unit with permanently installed cooking facilities (i.e., gas or electric range, cooktop) is deemed to have a cooking facility and thus requires arc fault protection.
- An “outlet branch circuit type combination arc fault circuit interrupter” may be used (instead of an AFCI breaker).
- Where a branch circuit feeds receptacles (rated 125 volt, 20 amps or less) that are associated with but outside the dwelling unit such as in a yard, accessory building, or detached garage, AFCI protection is **not required**.
- Combination arc fault protection refers to the ability of the breaker to monitor both series and parallel arcs.
- Non-combination arc fault breakers do not have parallel and series protection and may only be used for replacement and not for new installations.
- Dual AFCI / GFCI breakers provide ground fault protection and combination arc fault protection.

## 26-704 - PROTECTION OF RECEPTACLES BY A GROUND FAULT CIRCUIT INTERRUPTER OF THE CLASS A TYPE (SEE APPENDIX B)

All 5-15R or 5-20R receptacles installed outdoors and within 2.5m of the finished grade shall be protected by a GFI of the Class A type. All decks, patios, and surfaces accessible to foot traffic shall be considered finished grade.

Parking lot and commercial building receptacles are **no longer** exempted from protection.

A single receptacle for a septic pump out is exempt.

In accordance with the manufacturer’s instructions, when a receptacle is required for an indoor or outdoor wheelchair or mobility lift, it shall be a single receptacle connected to a separate circuit and shall not be arc fault or ground fault protected.

Finished Grade Level – Shall include walking surfaces such as, but not limited to, decks and balconies.

## 26-706 - TAMPER RESISTANT RECEPTACLES (SEE APPENDIX B)

All receptacles of CSA configuration 5-15R and 5-20R shall be tamper-resistant (TR) and shall be so marked, when installed in childcare facilities, guest rooms and guest suites of hotels and motels and dwelling units.

For pre-schools and elementary education facilities, receptacles shall be required to be tamper-resistant (TR) when installed in:

- The shared areas in joint facilities which may be accessed by children up to elementary school age shall also require tamper resistant receptacles.
- Portable classrooms shall be built with TR receptacles if attached to or intended for an elementary school.

- Relocated portable classrooms shall be dealt with on a case-by-case basis. However, if the wiring requires maintenance due to wear and tear, the receptacles shall be made to comply.

#### NOTES:

- This shall include all receptacles installed on or in buildings or structures associated with the residential occupancy (i.e., garages, sheds, carports, etc.).
- Please check with the Electrical Inspection department if further clarification is required.

## 26-710 - RECEPTACLES FOR MAINTENANCE OF EQUIPMENT ON ROOFTOPS (SEE APPENDIX B)

A receptacle is now required, for maintenance purposes, on all commercial or industrial buildings that have rooftop electrical equipment such as RTU's, ventilation, etc. This receptacle shall be:

- protected by a ground fault circuit interrupter of the class "A" type;
- supplied by a separate branch circuit that does not supply any other outlets or equipment;
- CSA configuration 5-20R;
- located within 7.5 m (24') of rooftop equipment;
- at least 750 mm (30") off finished roof; and
- protected from mechanical damage.

**A receptacle that is an integral part of the rooftop unit, supplied by a separate circuit as per Rule 26-710, meets the intent of this rule.**

Replacement of a rooftop unit will not require an upgrade to meet the intent of this rule.

## 26-720 - GENERAL (SEE APPENDICES B & G) - RECEPTACLES INSTALLED IN CUPBOARDS

Receptacles installed in drawers for appliances such as USB chargers, hair dryers, curling irons, food processors, etc. **shall be approved as part of the assembly and power shall be disconnected from the receptacle as soon as the drawer begins to close.** The circuit shall be AFCI protected and if located within 1.5 m (5') of a sink, bathtub or shower stall it shall be GFCI protected. Receptacles shall be tamper-resistant (TR).

## 26-722 - RECEPTACLES FOR DWELLING UNITS (SEE ALSO 2-022) – KITCHEN RECEPTACLES

At least one receptacle installed at each permanently fixed island counter space with a **continuous** long dimension of 600 mm (24") or greater and a short dimension of 300 mm (12") or greater.

At least one receptacle installed at each peninsular counter space with a **continuous** long dimension of 600 mm (24") or greater and a short dimension of 300 mm (12") or greater.

**Continuous counter space excluding sinks or cooktops**

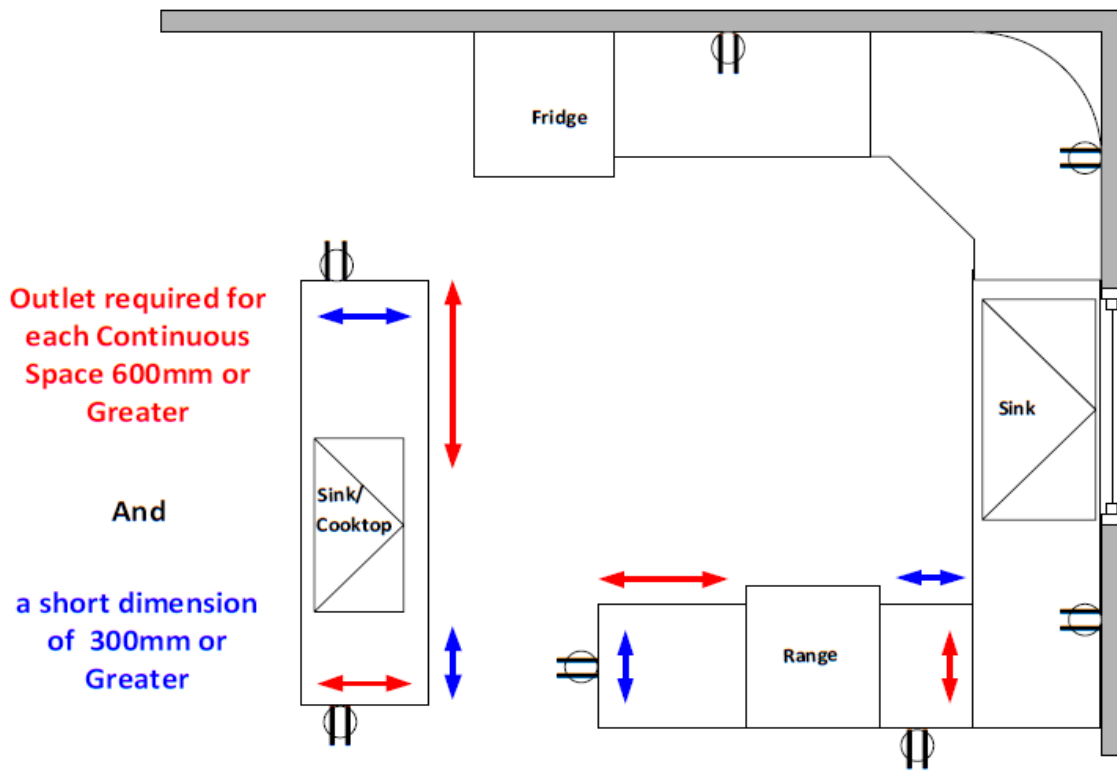

**26-724 - RECEPTACLES FOR SINGLE DWELLINGS (SEE APPENDIX B) - GARAGE DOOR OPENERS**

At least one receptacle shall be provided in a garage for cord connected garage door openers and located adjacent to and within 1 m (39") of each overhead garage door opener.

**Δ 26-806 - HEATING EQUIPMENT RATED 117KW OR LESS (SEE APPENDIX B)**

**(1)(5)(6)(7) - Gas furnaces**

The furnace shall be provided with a dedicated circuit. The disconnect shall be located as required by the CEC. Garage unit heaters must also meet all these requirements and provide a point of disconnect without passing in front of the furnace. See also Rule [10-700](#).

**(1)(2)(3)(4)(5) – Central Heating Unit (used as primary heating source)**

The central heating unit and associated circulation pumps when cord connected shall be fed from a separate circuit exempted from 26-656 (AFCI) and shall use single receptacles labelled for boiler use only.



## 26-956 - SUBMERSIBLE PUMPS INSTALLED IN BODIES OF WATER

Electrical Installations MUST be maintained by a Saskatchewan Licensed Electrical Contractor. All equipment shall be approved to an acceptable Canadian Standard.

Electrical Inspections shall be notified, and a permit submitted yearly, regarding pump installations **in or on bodies of water** where the voltage exceeds 150 volts-to-ground.

Pumps installed in or on bodies of water shall be provided with GFI protection set at not greater than 10ma for an operating time of 2.7s regardless of the location of the motor.

The area around the submersible pump, pump motor, or pump platform shall be protected from public access by isolation and so marked with a buoy. Buoys shall meet the private buoys regulations and installed as per the navigable waters act.

Pump controllers and cables installed on shore shall be protected by fencing or other acceptable means if they are susceptible to damage from animals in accordance with 2-200.

Signage marked “DANGER \_\_\_\_\_ VOLT PUMP” shall be visible from land and water, at the controller structure facing the water and at access points to the platforms.

Buoys shall meet the Private Buoys Regulations and shall be installed as per the Navigable Waters Act.

Plans must be submitted for review prior to application for deviation in accordance with [2-014 \(h\)](#).

Deviation is required as per [2-030](#). Application must include approval documentation from the AHJ for navigable water systems and the plans review letter.

## SECTION 28 – MOTORS AND GENERATORS

### 28-104(1) - MOTOR SUPPLY CONDUCTOR INSULATION TEMPERATURE RATING AND AMPACITY (SEE APPENDIX B)

Supply conductors to a motor connection box shall have an insulation temperature rating equal to or greater than that required by Table 37 (i.e., heating circulating pumps, automotive car lifts, etc.) **unless the motor is otherwise marked.**

### 28-110(1) - FEEDER CONDUCTORS

**Aeration Fan Services** - for the supply of motors shall be sized in accordance with Section 28 of the CEC.

The service calculation is based on the total number of fans permanently wired into the electrical panel. The motor disconnect shall be installed within sight of and within 9 meters (30') of the motor or be lockable at the source. If receptacles are installed to plug in the motors, then the service may be calculated by the number of fans to be utilized at one time.

### 28-300 - OVERLOAD PROTECTION REQUIRED

**Caution shall be used when connecting bin fans.**

Thermistors do not provide overload protection. The leads labelled as thermostat are the thermistor.

All motors exceeding 1 hp shall indicate that they have overload protection installed or have suitable overload protection field installed at the time of installation.

### 28-604(1) - LOCATION OF DISCONNECTING MEANS

Lock off devices shall be an approved device designed for the disconnecting means.

## SECTION 30 – INSTALLATION OF LIGHTING EQUIPMENT

Rules in 30-500 have all been removed from the CEC.

## SECTION 32 – FIRE ALARMS AND FIRE PUMPS

**Installation of smoke alarms and carbon monoxide (CO) alarms in dwelling units**

**For the purpose of the building code requirements:**

- New construction of residential units shall be provided with interconnected smoke alarms & CO alarms wired as per Section 32 and located as required by the Saskatchewan Amendments of the National Building Code (NBC) 2015 which can be found in the Appendix of The Uniform Building and Accessibility Standards Regulations (U-1.2 REG 5) available at [www.qp.gov.sk.ca](http://www.qp.gov.sk.ca).

## SECTION 34 – SIGNS AND OUTLINE LIGHTING

### 34-000 - SCOPE - SIGNS AND OUTLINE LIGHTING

#### **Signs**

Each sign shall have at least one label with the electrical ratings and certification mark readily accessible without the use of tools as per C22.2 No. 207-M89 and visible from the ground. This would include one label on one letter for multi letter/symbol signs.

For Retrofits to LED see Rule [2-106](#).

#### **Permits**

-  Permit fees for signs shall include the wiring to the sign and are as per the Electrical Fee Schedule. For LED retrofits the permit fees shall reflect the labour and material required for the installation.

### 34-106 – LOCATION (LED DRIVER)

LED drivers shall be installed in an accessible location as per Rule 2-312 when installed in attics, bulkheads, or similar locations.



## SECTION 36 – HIGH VOLTAGE INSTALLATIONS

### 36-004 - GUARDING

#### Minimum approach distances from exposed energized electrical conductors for qualified electrical workers

Nominal ph to ph Voltages*	Qualified Electrical Worker MAD		Qualified Electrical Worker MHAD	
	ph to gnd	ph to ph	ph to gnd	ph to ph
300 V	Avoid Contact		-	
750 V	0.35 m	0.35 m	-	
4.16 kV	0.65 m	0.65 m	-	
15 kV	0.70 m	0.75 m	-	
25 kV	0.75 m	0.85 m	-	
34.5 kV	0.80 m	1.00 m	-	
72 kV	0.95 m	1.25 m	1.05 m	1.35 m
138 kV	1.20 m	1.75 m	1.35 m	1.90 m
230 kV	1.80 m	2.80 m	2.00 m	3.10 m

### 36-312 - GROUNDING OF METALLIC FENCE ENCLOSURES

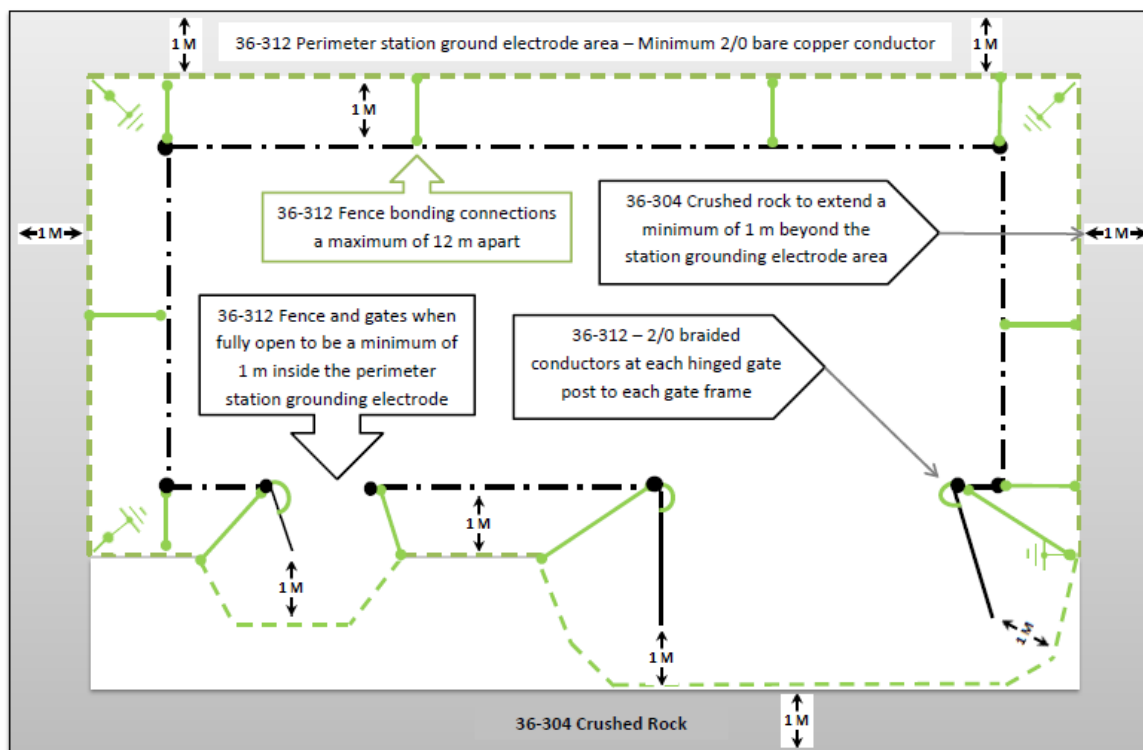

36-302 – Minimum 4 driven ground rods  
 Grounding grid engineered as per 36-304 Appendix B and Standard CEA 249 D 541  
 Table 51 and 52 may require more ground rods



## SECTION 62 – FIXED ELECTRICAL SPACE AND SURFACE HEATING SYSTEMS

### 62-114 - OVERCURRENT PROTECTION AND GROUPING (SEE APPENDIX B)

<b>Electric Furnace and Other Heating Equipment Single Phase 240V 62-114(6) and (7)</b>			
<b>Nameplate Furnace or Rating (KW)</b>	<b>Conductor Size at 75°C Equipment Marking 75°C</b>		<b>Fuse/Breaker Rating</b>
	<b>Copper</b>	<b>Aluminum</b>	
5 KW	No. 12 AWG R90	No. 10 AWG R90	30 Ampere
10 KW	No. 8 AWG R90	No. 6 AWG R90	60 Ampere
15 KW	No. 4 AWG R90	No. 2 AWG R90	100 Ampere
18 KW	No. 4 AWG R90	No. 2 AWG R90	100 Ampere
20 KW	No. 3 AWG R90	No. 1 AWG R90	125 Ampere
23 KW	No. 3 AWG R90	No. 1 AWG R90	125 Ampere
25 KW	6	No. 0 AWG R90	150 Ampere
30 KW	No. 0 AWG R90	No. 000 AWG R90	175 Ampere

A sample selection for a 20 KW furnace follows: The ampacity of the conductors supplying the furnace and the size of the overcurrent devices are determined by applying Rule 62-114.

The overcurrent device for the service must be sized so that the total connected load of the heating equipment does not exceed 80% of the rating of the overcurrent device in accordance with subrule (6). In this case, the load is 83.3 amps; the minimum size of overcurrent device is  $83.3/0.8 = 104$  Amperes. Rule 62-114(8) the next available fuse is 125 A.

Since this fuse is supplying a heating load, Rule 14-610 requires that the fuses be a time delay type or HRC Form I.

The conductor size is determined by applying Rule 62-114(7). The conductor must have the ampacity sufficient to carry the load and must have an ampacity rating at least 80% of the rating or setting of the branch circuit overcurrent device. A conductor rated at 100 amperes, e.g., #3 AWG R90 (75°C column of Table 2) would satisfy these requirements.



## 62-130 - HEATER CONTROLS INSTALLED IN PROXIMITY TO SINKS, TUBS, OR SHOWER STALLS

1. A manually operable control for an electric heater in a bathroom is to be located at least 1 m (39") from the bathtub or shower stall.
2. If 1 m (39") is not practicable, it is permitted to be located not less than 500 mm (20") from a bathtub or shower stall, provided it is:
  - a) protected by a ground fault circuit interrupter of the Class A type; or
  - b) supplied by a Class 2 circuit operating at not more than 42.4 V peak or DC.

## 62-132 - HEATING DEVICES INSTALLED IN PROXIMITY TO SINKS, TUBS, OR SHOWER STALLS

Heating devices i.e., baseboard heaters etc. installed less than 1m (39") from a tub, shower or sink shall be protected by a Class A type GFI.

## 62-200 - ELECTRIC SPACE HEATING (SEE APPENDIX B)

Table 67 has been added to the code to provide installation clearance requirements for space heating systems i.e., in-floor systems, baseboard heaters, etc. Receptacles shall not be mounted within 200 mm (8") of electric space heating. See also drawing B62-3.

## SECTION 64 – RENEWABLE ENERGY SYSTEMS

**NOTE:** Rules for marking, warning notices and Diagrams - see [Appendix M](#)

### △ 64-002 - SPECIAL TERMINOLOGY

In this section, please refer to the attached diagram for terminology and components of a DC interconnected system with recombiners.

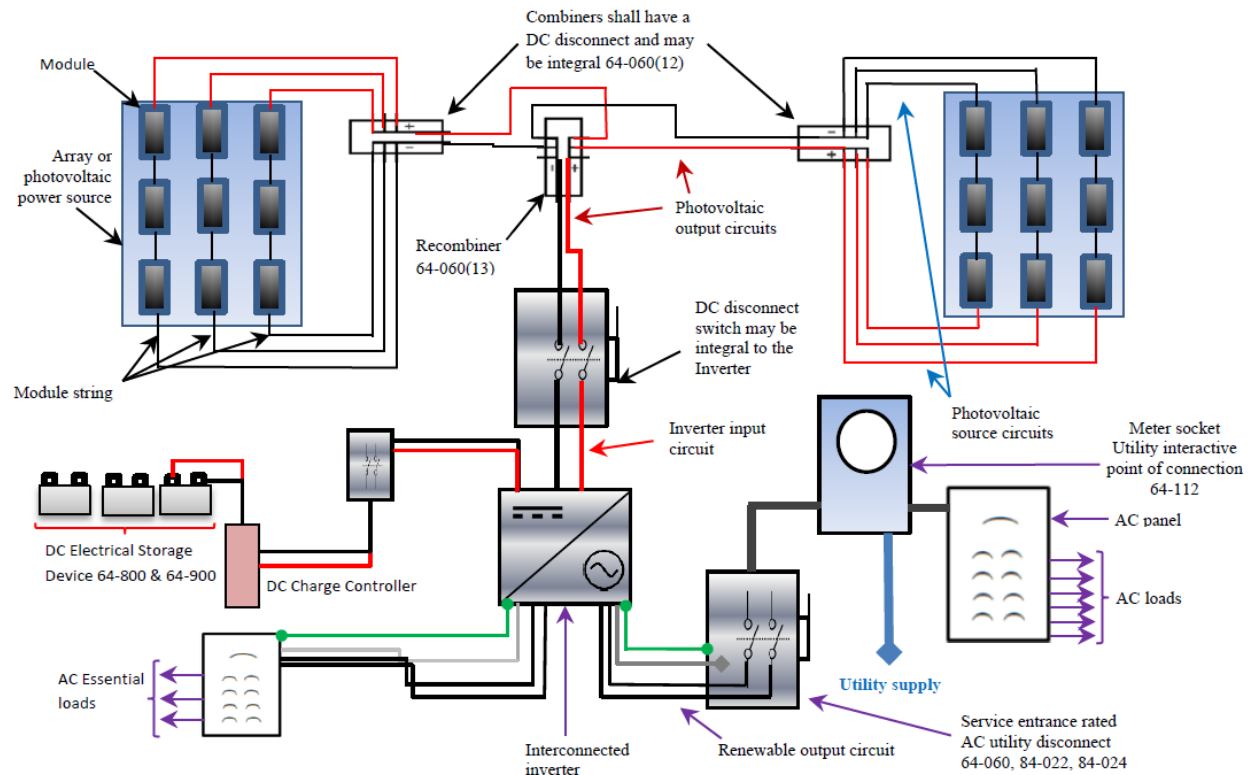

**Interconnected System with Recombiner, Essential Power and Energy Storage**

Figure 64-1

### 64-058 - OVERCURRENT PROTECTION (ALL RENEWABLE ENERGY SYSTEMS)

Where circuit conductors are connected to more than one source, all overcurrent devices shall be located in such a way that they provide overcurrent protection from all sources.

Overcurrent devices marked or **approved only for AC use shall not** be used in DC circuits.

Circuit breakers that are marked “Line” and “Load” have been evaluated for connection only in the direction marked.

**NOTE:** To facilitate the inspection of the installation contractor photos can be attached to the permit in the Permit System or made available on site to show the wiring installation, bonding of the racking and installation of the equipment.



## 64-060 - DISCONNECTING MEANS (SEE ALSO 84-022, 84-024 & APPENDIX M)

- (2) The disconnecting means shall be capable of being energized from both sides, indicate open or closed, lockable in the open position, conform to Section 14, capable of opening at the rated load, capable of being closed under fault conditions and located within sight and 9 m (30') of or integral to the equipment.
- (6) Solid state devices shall not be used as isolating switches or as a disconnecting means.
- (7) Output circuits rated 48V and greater shall have a means to disable and isolate them.
- (8) Disconnecting means shall be provided to disconnect a fuse from all sources of supply if the fuse is energized from both directions as required by Rule 14-402.
- (9) Disconnecting means on DC circuits shall be marked for the purpose.
- (12) For combiners, a single disconnect within 2 m (6') or integral to and interlocked with the combiner door, is required for the photovoltaic output circuit rated in accordance with Rule 64-206.
- (13) For recombiners a single disconnect within 2 m (6') or integral to and interlocked with the recombiner door, is required for the inverter input circuit rated in accordance with Rule 64-206.

## △ 64-062 - WIRING METHODS

- (1) Insulated conductors for DC renewable energy sources, between the array and the interactive inverter, installed inside a building or structure, must be contained in metallic raceways, metallic enclosures or cables which are metal-sheathed or metal armoured.

## 64-066 - UNGROUNDED RENEWABLE ENERGY POWER SYSTEMS

Renewable energy systems are permitted to operate with ungrounded source and supply circuits if the system complies with the following:

- All source and supply conductors must have overcurrent protection (positive and negative conductors) except as per [64-214\(1\)](#);
- Inverters or charge controllers must be suitable for the purpose;
- The system must be provided with ground fault protection; and
- A suitable warning must be installed at each junction box, disconnect or any other device where these circuits can be exposed during service. See [Appendix M](#).

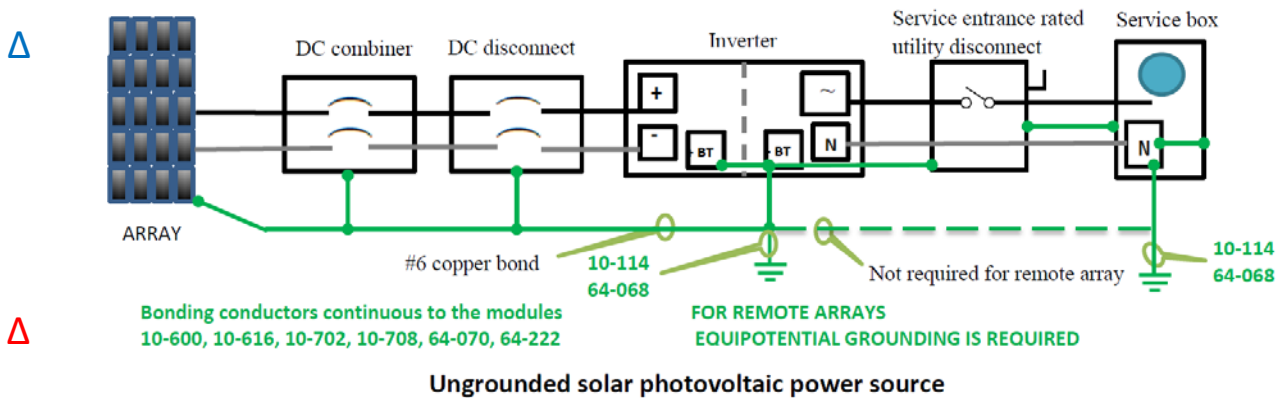

Figure 64-2

**Legend**

**BT – equipment bonding terminals**

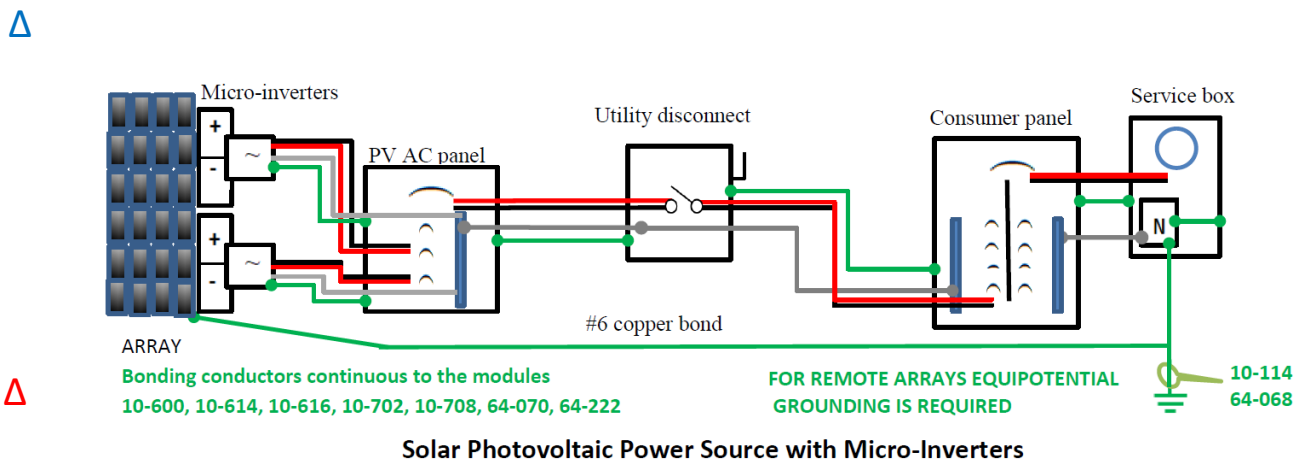

Figure 64-3

**64- 074 - Warning notices and diagrams (see Appendices B & M)**

Buildings and structures with both Utility and a renewable energy system shall have a permanent placard posted on or near the utility service box indicating the interconnected systems, energy storage systems, generator back-up and the locations of the equipment and their disconnects through the use of warning notices and diagrams (placards) permanently installed in accordance with requirements of this section. See also [64-218](#), [64-902](#), [Appendix M](#).

Addition of new systems to an existing installation shall require a new and updated placard to include all renewable systems, energy storage systems and generators.



## 64-110 - UNBALANCED INTERCONNECTIONS (INVERTERS)

Single phase inverters shall not be connected to a three-phase utility system unless:

- The inverters used are certified as utility interconnected and approved for use in three-phase systems;
- The single-phase inverters are designed such that under normal operating conditions the resulting three-phase system voltages are balanced within the limits of the supply authority;
- The installation complies with Rules 84-008 and 84-018;
- Confirmation that the installation is acceptable to the supply authority; and
- The installation meets the inverter manufacturer's requirements.

## Δ 64-112 - UTILITY-INTERACTIVE POINT OF CONNECTION (INVERTERS)

- (1) The output of an interactive inverter shall be connected to the supply authority system in accordance with Section 84.
- (2) The output of an interactive inverter is allowed to be connected to the line side of the service disconnecting means at a dual lug meter socket or other source(s). See figure 64-4.

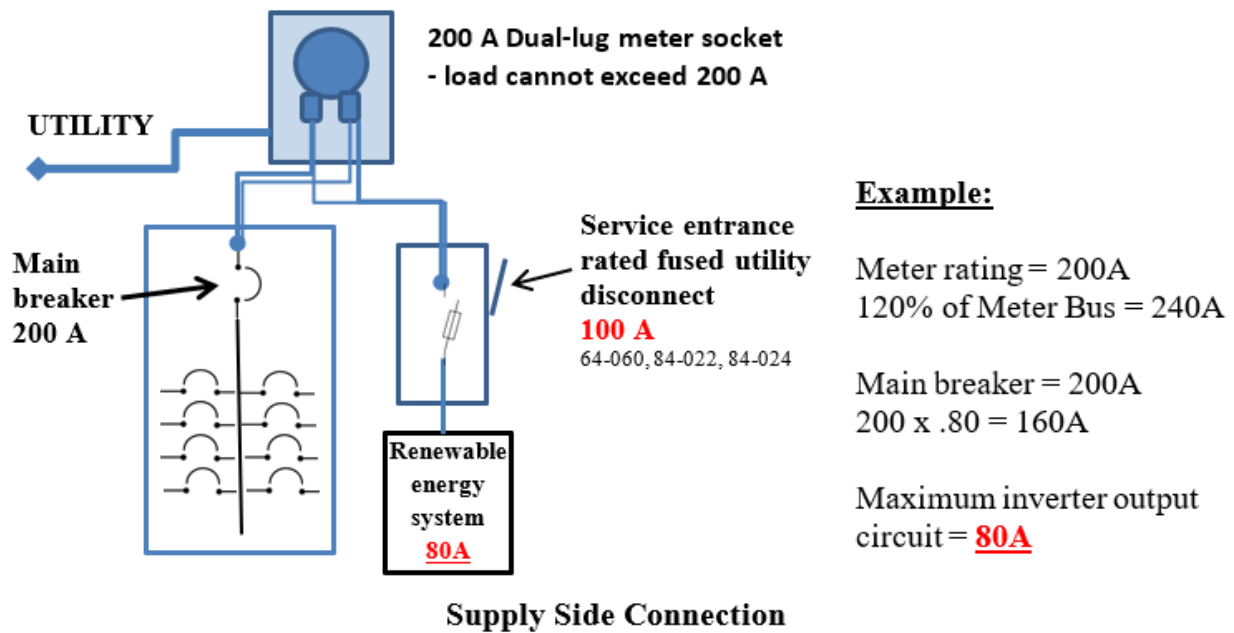

Figure 64-4

- (3) The output of an interactive inverter is allowed to be connected to the load side of the service disconnecting means provided that each source interconnection is made at a dedicated circuit breaker or fused disconnecting means. This point of connection shall be positioned at the opposite (load) end of the panelboard, busbar or conductor from the input feeder location or main circuit breaker location. See figure 64-5.

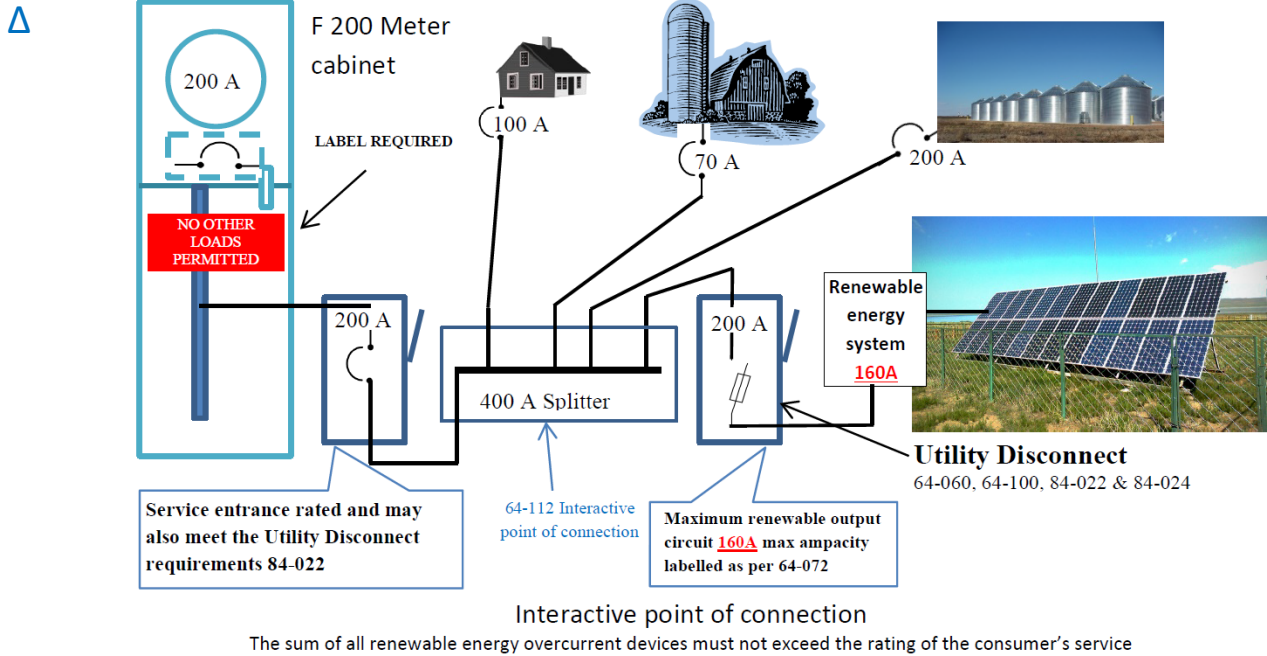
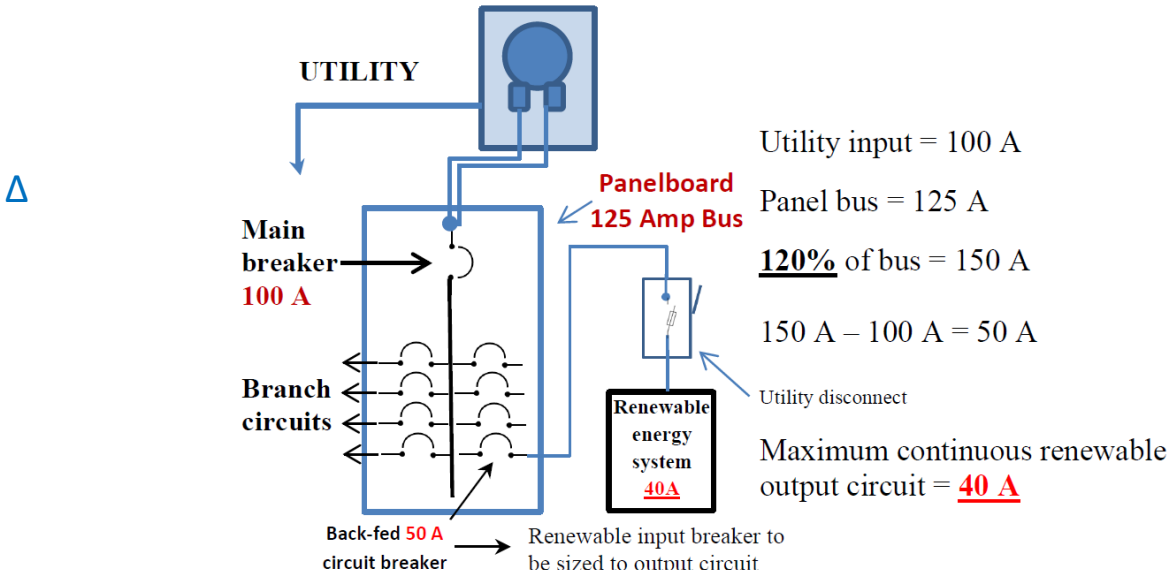

Figure 64-5

**Non-dwelling units**

(4)(c) The sum of the overcurrent devices supplying power to a busbar or conductor is allowed to exceed the rating of the busbar or conductor to a maximum of 120%. See figure 64-6.



Load side connection – non-dwelling unit

Figure 64-6





## Dwelling units

(4)(d) The sum of the overcurrent devices supplying power to a busbar or conductor is allowed to exceed the rating of the busbar or conductor to a maximum of 125%. See figures 64-7 & 64-8.

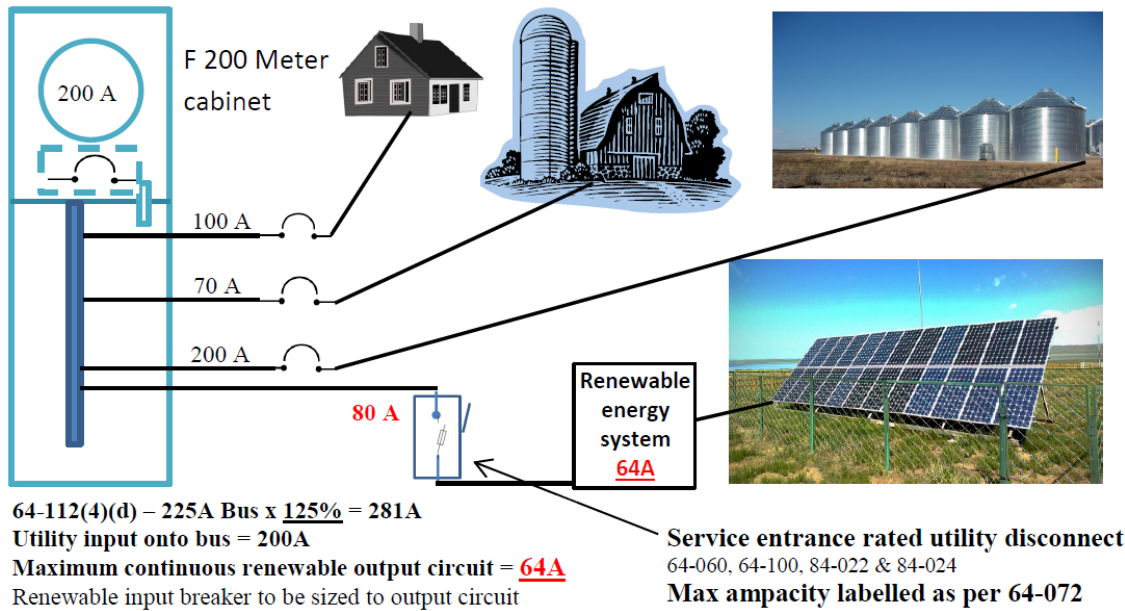

### F200 Farm/Acreage installation

Figure 64-7

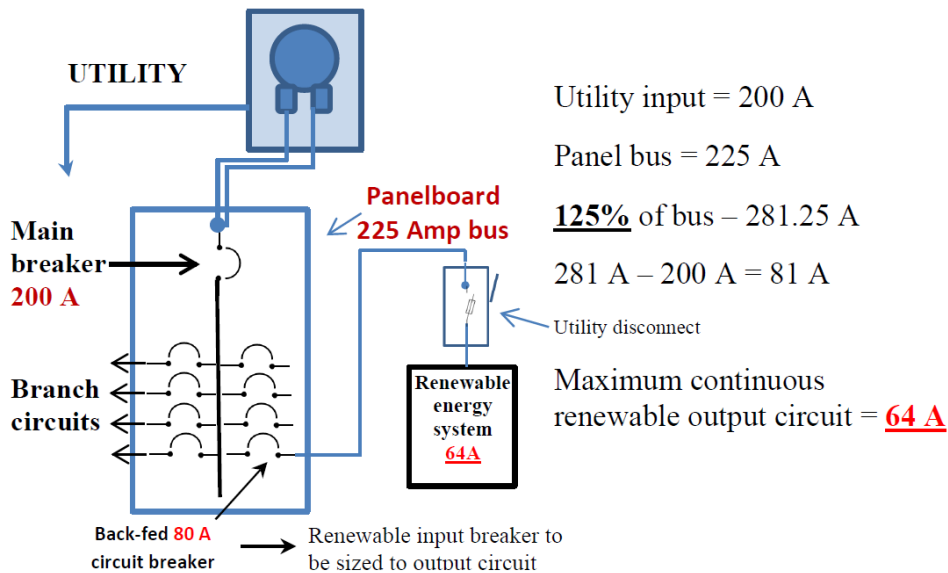

### Load side connection – dwelling unit

Figure 64-8



## 64-202 - VOLTAGE OF SOLAR PHOTOVOLTAIC SYSTEMS

- (1) The maximum photovoltaic source and output circuit voltage shall be the rated open circuit voltage ( $V_{oc}$ ) of the photovoltaic power source X 125%; or
- (2) The source and circuit output voltage ( $V_{MPC}$ ) may be calculated using the open circuit voltage ( $V_{oc}$ ) of the photovoltaic power source, the difference between 25 °C and the lowest expected daily minimum temperature ( $T_m$ ) (available from Environment Canada “Canadian Climate Norms”) and the voltage temperature coefficient ( $T_k$ ) as specified by the manufacturer.

$$V_{MPC} \text{ _____} = V_{oc} \times [1 + (T_m - 25) \times T_k]$$

		Calculation of $V_{MPC}$				
	$V_{MPC}$	=	$V_{oc}$	x	( 1+ ( ( $T_m$ - 25) x $T_k$ ( % / °C ) ) )	
<u>Step 1</u>	$V_{MPC}$	=	45.8	x	( 1+ ( ( -23.2 - 25) x -0.31 ( % / °C ) ) )	
<u>Step 2</u>	$V_{MPC}$	=	45.8	x	( 1+ ( ( -23.2 - 25) x -0.0031 ) )	
<u>Step 3</u>	$V_{MPC}$	=	45.8	x	( 1+ ( -48.2 x -0.0031 ) )	
<u>Step 4</u>	$V_{MPC}$	=	45.8	x	( 1+ 0.1494 )	
<u>Step 5</u>	$V_{MPC}$	=	45.8	x	1.1494	
<u>Step 6</u>	$V_{MPC}$	=	52.6434	Volts		
	TOTAL	=	947.582	Volts		
	$V_{oc}$	=	45.8	Volts		Note: Input information into blue cells only.
	$T_m$	=	-23.2	°C		
	$T_k$	=	-0.31	%		
	# of panels	=	18			

- (3) The photovoltaic source and output circuits for installations in or on a dwelling unit shall be permitted to have a voltage not exceeding 600V DC.
- (4) The voltages of solar photovoltaic systems may exceed 750V DC but not more than 1500 V DC and shall not be required to meet the requirements of 36-204, 36-208 & 36-214 provided they are maintained by qualified persons, are inaccessible to the public, and labelled “DANGER \_\_\_\_\_ V DC”. See [Appendix M](#).

## 64-210 - WIRING METHODS

- (2) & (3) Where the source and output circuits operate at a maximum system voltage greater than 30V, the wiring is deemed inaccessible to the public and not readily accessible if it is:
  - contained in a raceway;
  - contained behind metal screening or guarding with holes not exceeding 13mm (1/2”) x 13mm (1/2”);
  - elevated 3 m or more above grade level; or
  - located within a fenced enclosure in accordance with Rule 26-304, 26-312, and 26-314
- (4) Conductors and cables shall be mechanically protected and supported as per this rule throughout the run;



- (5) **Rodent protection is required** on all insulated conductors or cables, with the exception of armoured cables or MI cables, installed on or above a building by enclosing them in material such as approved raceways, expanded metal, solid metal, metal screening (maximum 13 mm (1/2") x 13 mm (1/2") holes) or other acceptable protection.
- (7) RPV conductors shall be permitted for the module interconnections if they are contained in a raceway;
- (9) Types RPV and RPVU conductors installed inside a building or structure shall be contained in a metallic raceway. See [64-062](#).

**NOTES:**

- For rodent protection, module level arc fault protection must be part of the module and listed in the module manufacturers' installation instructions.
- **Modules cannot be drilled into for mounting of rodent protection.**

## 64-212 - INSULATED CONDUCTOR MARKING OR COLOUR CODING

RPVU or RPV conductors shall be coloured red for positive, black for negative or permanent surface printing of the polarity on the insulated conductors. TECK 90 cables may be field marked in a permanent manner (heat shrink).

## 64-214 - OVERCURRENT PROTECTION FOR APPARATUS AND CONDUCTORS

Maximum photovoltaic source circuit short-circuit-current ( $I_{sc}$ ) is equal to the sum of the short circuit current for all the source circuits connected in parallel minus the short circuit current for one of the photovoltaic source circuits.

If the photovoltaic source circuit short-circuit-current ( $I_{sc}$ ) (sum of all parallel strings minus one string) exceeds the maximum series fuse rating (reverse current rating) (typically 15A or 20A) or the ampacity of the source circuit conductor, then OC protection will be required on each ungrounded conductor.

E.g., String  $I_{sc} = 9.5A \times 3(\text{strings}) = 28.5 - 9.5 = 19A \times 125\% = 23.75A$ ; DC fusing is required for 15A or 20A series fuse rating.

Where the value specified in Subrule 2) does not correspond to the standard rating of an overcurrent device, the next higher standard rating shall be permitted. For a two-wire ungrounded system, the overcurrent protection may be located in one source or output conductor only but must be in the same polarity for the entire system.

DC overcurrent devices shall be accessible and grouped where practicable.

**NOTE:**

- AC overcurrent protective devices must be readily accessible. See Rule 14-106.

## △ 64-216 - PHOTOVOLTAIC DC ARC-FAULT PROTECTION (SOLAR PHOTOVOLTAIC SYSTEMS)

Photovoltaic systems with a DC source or output circuit system voltage of 80V or greater, shall be DC arc-fault protected or provided with equivalent protection.

For photovoltaic systems not mounted on or above a building, (ground mounted systems) other than those buildings constructed for the sole purpose of housing solar equipment, where the conductors are installed in metallic raceways, metallic armoured cable, totally enclosed trays, or direct buried, and when complying with ongoing ground cover and vegetation control to mitigate the possibility of fire spread, a deviation of the DC arc-fault requirement may be requested as per 2-030.

A signed letter of understanding of the vegetation control requirement will be required from the installation owner.

## △ 64-218 - RAPID SHUTDOWN

A photovoltaic system rapid shutdown device shall be provided for a photovoltaic system installed on buildings or structures where the photovoltaic source or output **insulated conductors or cables** installed on or in buildings are more than 1m (39") from the photovoltaic array.

The rapid shut down initiating device, for single dwelling units, shall be located at the utility meter location.

For other than single dwelling units, one initiating device shall be at the utility meter location **and** a second initiating device at the permanent access to the building roof **or** within sight of and 9m (30') of the array.

If the utility disconnect serves a dual function as a rapid shutdown, it shall be labeled as such. (E.g., systems using micro-inverters or optimizers.)

Placards indicating the system is equipped with rapid shutdown, shall be located at the supply authority meter location and the consumer's service equipment location. The location of these placards (or additional placards) on buildings without exterior metering may require discussion with the local fire department i.e., near the gas meters, water standpipe, service splitter, fire annunciation panel, etc. See also [64-902](#).

## △ 64-802 - VENTILATION OF BATTERY ROOMS (SEE APPENDIX B)

Rooms or areas that contain batteries that vent hydrogen to the atmosphere shall be adequately ventilated and not subjected to temperatures in excess of 45 °C or less than the freezing point of the electrolyte in accordance with manufacturer's instructions.

## △ 64-804 - INSTALLATION (SEE APPENDIX B)

Batteries installed in residential dwelling units shall not be connected with an output voltage exceeding 50V dc and must be guarded to prevent accidental contact by persons or objects.

## 64-902 - MARKING



Any building or structure containing energy storage systems shall have a placard to indicate the location of the energy storage system and the disconnecting means. See also [64-074](#), [Appendix M](#).

## 64-918 - LOCATION AND SEPARATION REQUIREMENTS FOR ENERGY STORAGE SYSTEMS (SEE APPENDIX B)

Energy storage systems for use in dwelling units cannot exceed 1kWh, shall be marked “suitable for use in residential dwelling units” and shall not be installed below grade.

Systems exceeding 1 kWh but not greater than 20 kWh or an aggregate capacity not exceeding 40 kWh may be permitted in an attached garage of a dwelling unit, and not within 1m of any other energy storage system or as per manufacturer’s instructions.



## △ SECTION 68 – POOLS, TUBS AND SPAS

### 68-000 - SCOPE

**A pool shall be deemed to include:**

- permanently installed and storable swimming pools;
- hydromassage bathtubs;
- spas and hot tubs;
- wading pools;
- baptismal pools;
- decorative pools; and
- splash pads.

### 68-054 - UTILITY CONDUCTORS OVER POOLS

Electric utilities may not permit open service conductors to be located directly over a pool, hot tub, or spa.

**NOTE:**

- A structure that will adequately provide a permanent barrier between overhead conductors and the hot tub shall be acceptable as protection from overhead lines crossing above a hot tub and if the structure is metal and within 1.5 m of the hot tub, it shall be bonded to ground.

### 68-056 - UTILITY CONDUCTORS UNDER POOLS

Electric utilities may not permit service conductors to be located directly under a pool, hot tub, or spa.

**NOTE:**

- If locating or relocating a pool, hot tub, or spa, ensure it is not located directly over a Utility gas line. Contact Gas Utility for further information.

### 68-308 - OTHER ELECTRICAL EQUIPMENT

No other (unrelated) equipment is to be fed from a circuit feeding a hydro massage bathtub. Access must be provided to all electrical equipment including the pump motor.

**See Rule 2-122** - Minimum 400 mm (18") x 400 mm (18") access panel.



## SECTION 68 - POOL DIAGRAMS

### Canadian Electrical Code, Part I

### Section 68 – Pools, tubs & spas

#### 68-068 Ground fault circuit interrupters

- (6) Ground fault circuit interrupters shall be installed
- (a) in a location that will facilitate the testing required in Subrule(5);
  - (b) not closer than 3 m to the pool water except as permitted by item (c); and
  - (c) not closer than 3 m to the pool water in a spa or hot tub and not closer than 1.5 m to a hydromassage bathtub, unless the **ground fault circuit interrupter** is an integral part of an approved factory-built spa, hot tub, or hydromassage bathtub or is located behind a barrier that will prevent the occupant of the pool from contacting the device.

- (7) Except as permitted by Rule 68-070, the following equipment shall be protected by a ground fault circuit interrupter:

- (d) electrical equipment located within the confines of the pool walls or within 3 m of the inside walls of the pool and not suitably separated from the pool area by a fence, wall or other permanent barrier.

Electrical Service Equipment and any associated piping



#### 68-066 Luminaires and lighting equipment

- (5) Luminaires installed within 3 m of the pool surface or walls and not suitably separated from the pool area by a fence, wall or other permanent barrier, shall be electrically protected by a ground fault circuit interrupter

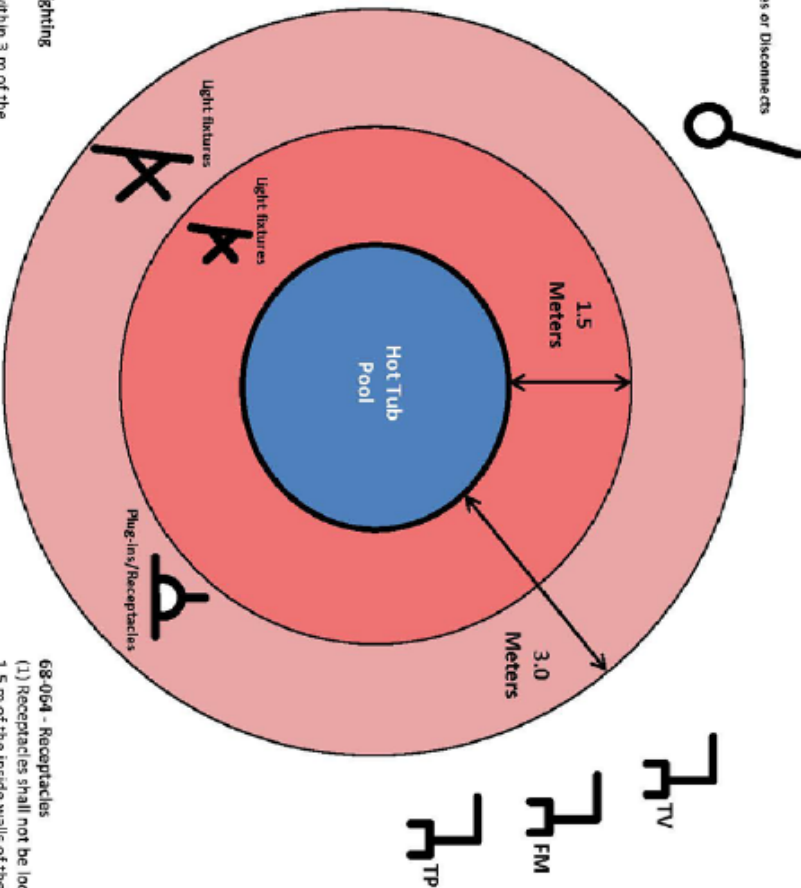

- 68-070 Other electrical equipment**
- (1) Loudspeakers installed beneath the pool surface shall be
    - (a) mounted in a recess in the wall or floor of the pool and enclosed by a separate, rigid, corrosion resistant metal screen; and
    - (b) connected to their audio isolating transformers by ungrounded wiring.

- (2) Communication equipment installed within 3 m of the inside walls of the pool shall be
  - (a) permanently fixed on the wall and located so that no part is within 1.5 m of the inside walls of the pool or can be used from the pool, unless actuated by means of a cord with an insulating link; or
  - (b) separated from the pool area by a fence, wall, or other permanent barrier.
- (3) Notwithstanding Subrule (2), communication jacks shall not be installed within 3 m from the inside walls of the pool.

TV – Television jack  
 FM – Stereo jack / speaker  
 TP – telephone jack

#### 68-064 - Receptacles

- (1) Receptacles shall not be located within 1.5 m of the inside walls of the pools.
- (2) Receptacles located between 1.5 m and 3 m of the inside walls of a pool shall be protected by a ground fault circuit interrupter of the Class A type.



## SECTION 68 - POOL DIAGRAMS

### Things you should know before installing a swimming pool

A pool is deemed to include:

- Permanently installed and storable swimming pools;
- Spas, hot tubs;
- Wading Pools, baptismal pools;
- Decorative pools;
- Splash pads.

**Permanently installed swimming pool** - means a pool constructed in such a manner that it cannot be disassembled for storage.

**Storable swimming pool** - means a pool constructed in such a manner that it may be readily disassembled for storage and reassembled to its original integrity.

**Spa, or hot tub** - means a pool or tub designed for the immersion of persons in heated water circulated in a closed system incorporating a filter, heater, pump and with or without a motor-driven blower but not intended to be filled and drained with each use.

**Decorative pool or baptismal pool** - means a pool that could be used as a wading pool or the immersion of persons, that is larger than 1.5 m (5') in any dimension, and that is readily accessible to the public.

**Overhead wiring** (includes overhead telephone, cable TV and power conductors)

Customer owned overhead wiring including insulated communication conductors, communication antenna distribution conductors, and neutral supported cables not exceeding 750 V shall be permitted to be located over a pool, diving structure, slide, observation stand, tower, or platform, providing there is a vertically clearance of 5 m (17') above the pool and/or pool equipment. This also includes the area extending 5 m (17') horizontally from the pool edge, and 5 m (17') measured radially.

**Utilities do not permit any service conductors to be located directly over a swimming pool or hot tub.**

Utility service conductors not exceeding 750V may be located adjacent to a pool or hot tub provided there is at least 5 m (17') measured radially from the edge of the pool, hot tub, and diving or play structure. 7.5 m (25') for conductors 750V and above.

(See figure to the right)

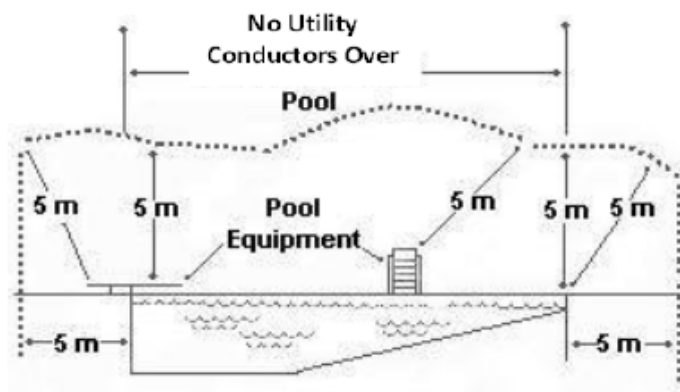



**Underground wiring (includes underground telephone, cable TV and power utility service cables)**

The horizontal separation between the inside walls of an in-ground pool or splash pad and underground conductors, except for bonding conductors or conductors supplying electrical equipment associated with the pool and protected by a ground fault circuit interrupter, shall not be less than:

<i>Type of Installation</i>	<i>Conductors Buried Directly in earth</i>		<i>Conductors in non-conducting Ducts</i>	
Communications conductors	1.5 m (5')		1 m (39")	
Power Conductors:	<i>CEC t-61</i>	<i>SaskPower t 2-3</i>	<i>CEC 68-054</i>	<i>SaskPower t 2-3</i>
0 - 750 V	1.5 m (5')	2.0 m (6')	1.0 m (39")	1.0 m (39")
751 - 15,000 V	3.0 m (10')	2.0 m (6')	1.5 m (5')	2.0 m (6')
15,001 - 28,000 V	6.0 m (20')	6.0 m (20')	2.0 m (6')	2.0 m (6')

**Receptacles (wall plugs)**

Receptacles shall not be located within 1.5 m (5') of the inside walls of a pool.

Receptacles located between 1.5 m (5') and 3 m (10') of the inside walls of a pool shall be protected by a ground fault circuit interrupter outside of the 3m (10') distance.

Ground fault circuit interrupters shall not be installed closer than 3m (10') to the pool water unless the ground fault circuit interrupter is an integral part of an approved factory-built spa or hot tub and is located behind a barrier that will prevent the occupant of the tub from contacting the device.

**Other electrical equipment (air conditioning equipment, pumps, etc.)**

Electrical equipment located within 3 m (10') of the inside walls of the pool and not suitably separated from the pool area by a fence, wall, or other permanent barrier, shall be protected by a ground fault circuit interrupter.

**Electrical utility meter**

A swimming pool or hot tub shall not be located within 3 m (10') of the electrical utility meter unless it is suitably separated from the pool area by a fence, wall or other permanent barrier that provides no less than 1 m (39") clearance about the electric meter. *(Metal poles used for pool servicing can present a shock hazard, to persons working in the pool area, contacting the electric service equipment)*

**Lighting**

Lighting installed below, or within 3 m (10') of the pool surface or walls, and not suitably separated from the pool area by a fence, wall, or other permanent barrier shall be electrically protected by a ground fault circuit interrupter.

Standards or supports for lighting shall not be installed within 3 m (10') of the inside walls of a swimming pool unless a ground fault circuit interrupter protects such lighting.

**Bonding to ground**

Pool reinforcing steel and the pool shell shall be bonded at four equally spaced points around the pool. All metallic components associated with the pool and metallic fences within 1.5 m (5') of the pool shall be bonded to ground by a copper conductor.



## SECTION 70 – TINY HOME REQUIREMENTS

A Tiny Home is a dwelling unit built on a flatbed trailer designed for use of a single family and built to be relocated.

Permits will be required for the service connection of Tiny Homes.

Unless approved by a certification agency, these dwelling units shall be wired to the CEC requirements. Permits are required by a licensed electrical contractor for the wiring of a tiny home. RTM labels shall be installed to identify the contractor and permit number under which the tiny home was wired.

## SECTION 72 – MOBILE HOME AND RECREATIONAL VEHICLE PARKS

### 72-102(2) - DEMAND FACTORS FOR SERVICE AND FEEDERS

#### △ 72-102(2), (3), (4), Table 71

##### Campground service calculation Example A

A campground has 30 sites. 10 of the sites have a pedestal with a 50 A, 240 V receptacle and a 30 A, 120 V receptacle. 20 of the sites have a pedestal with a 30 A, 120 V receptacle and a 20 A, 120 V receptacle. Panel A is protected by a 100 A breaker (rated at 80%) and serves the shower building. Panelboard B is protected by a 100 A breaker (rated at 100%) and serves site lighting, etc.

What size 120/240 V service is required?

Panelboard 'A' =	$[(100 \text{ A} \times 240 \text{ V}) \times .80]$	=	19,200 watts
Panelboard 'B' =	$[(100 \text{ A} \times 240 \text{ V}) \times 1]$	=	24,000 watts
1-9th sites at 50A =	$9 \times 12,000$	=	108,000 watts
10th site at 50A =	$[(1 \times 12,000) \times .80]$	=	9,600 watts
11th - 15th sites at 30A =	$[(5 \times 3,600) \times .90]$	=	16,200 watts
16th - 30th sites at 30A =	$[(15 \times 3,600) \times .80]$	=	43,200 watts
	Total watts	=	220,200 watts
	$220,200 \div 240 \text{ V}$	=	917.5 Amps

This campground would require a 1200 Amp 120/240V service with an 80% rated main breaker.

#### △ 72-102(2), (3), (4), Table 71

##### Campground service calculation Example B

A campground has 40 sites. 14 of the sites have a pedestal with a 50A, 208V single phase receptacle and a 30A, 120V receptacle. 17 of the sites have a pedestal with a 30A, 120V receptacle and a 20A, 120V receptacle. 9 of the sites have a 20A, 120V receptacle. Panel A is a 120/208V single phase panelboard with a 60A breaker (rated at 80%) and serves the shower building. Panel B is a 120/208V 3 phase panelboard protected by a 150A breaker (rated at 100%) and serves the site lighting etc.

What size 120/208V service is required?

Panelboard 'A' =	$[(60 \text{ A} \times 208 \text{ V}) \times .80]$	=	9,984 watts
Panelboard 'B' =	$[(150 \text{ A} \times 208 \text{ V} \times 1.73) \times 1]$	=	53,976 watts
1-9th sites at 50A =	$9 \times 12,000$	=	108,000 watts
10th - 14th sites at 50A =	$[(5 \times 12,000) \times .80]$	=	48,000 watts
15th site at 30A =	$[(1 \times 3,600) \times .90]$	=	3,240 watts
16th – 31st sites at 30A =	$[(16 \times 3600) \times .80]$	=	46,080 watts
32nd – 35th sites at 20A =	$[(4 \times 2,400) \times .80]$	=	7,680 watts
36th – 40th sites at 20A =	$[(5 \times 2,400) \times .75]$	=	9,000 watts
	Total Watts	=	285,960 watts
	$285,960 \div (208 \text{ V} \times 1.73)$	=	794.69Amps

This campground will require a 1000 Amp 120/208 V 3 phase service with an 80% rated main.



## △ SECTION 76 – TEMPORARY WIRING

### 76-006 - SERVICE ENTRANCE EQUIPMENT

When located in an outdoor location, these services must be of weather-proof construction.

- △ If a temporary free-standing service persists beyond 12 months, it shall conform to the rules of 2-300 in these Interpretations.

### 76-016 - RECEPTACLES

All temporary service receptacles of 5-15R and 5-20R are to be ground fault protected. In use 'extra duty' covers will not be required on temporary construction services.

Receptacles installed in a building under construction that are part of the permanent wiring system will not require ground fault protection.

## SECTION 78 – MARINE WHARVES, DOCKING FACILITIES, FIXED AND FLOATING PIERS AND BOATHOUSES

### 78-050 - RECEPTACLES

Receptacles for use on fixed or floating piers, docking facilities, marine wharves or boat houses shall be GFI protected and mounted above the permanent or maximum normal water level to avoid immersion.

### 78-052 - BRANCH CIRCUITS AND FEEDERS

GFI protection shall be provided to de-energize all normally ungrounded conductors for distribution equipment in or on fixed or floating piers, docking facilities, marine wharves, or boat houses with a setting sufficient to allow normal operation of the equipment but in no case greater than 30 mA.

## SECTION 84 – INTERCONNECTION OF ELECTRIC POWER PRODUCTION SOURCES

### 84-000 - PORTABLE GENERATORS

As with all electrical equipment, portable generators and associated equipment must be approved and carry the mark of a recognized certification agency. Although recommended in the manuals of many power take-off generators, welding cable is not an approved wiring method and will not be accepted. Recessed male receptacles shall be used as an interface to the generator. Anderson Plugs shall be permitted when installed in a junction box. Wiring methods to the interface receptacle shall meet the requirements of section 12 for permanently installed equipment.

Generators and associated equipment i.e., transfer switches, load bank, etc. must be installed by a licensed electrical contractor and the appropriate permit must be submitted. See [2-014](#).

See [Appendix M](#) for diagrams to show typical residential and farm generator installation configurations. For other installation configurations contact a licensed electrical contractor or Electrical Inspections.

**Caution** – owners shall ensure that generators being interconnected with renewable systems are compatible.

## 84-002 - GENERAL REQUIREMENT

A closed transition transfer switch requires a Utility Interconnection Agreement before this equipment can be put into service. Please contact the utility to complete this agreement.

**Caution** – owners shall ensure that generators being interconnected with renewable systems are compatible.

## 84-020 - DISCONNECTING MEANS - ELECTRIC POWER PRODUCTION

For interconnection of renewable energy sources, more than one disconnect may be permitted in a multiple metered unit provided they are located at one location.

## 84-022 - DISCONNECTING MEANS - SUPPLY AUTHORITY SYSTEM

The utility disconnect shall provide a single point of disconnect for the supply authority **for all electric power production sources** on a property.

**Confirmation of acceptance is required during the interconnection agreement process. Please contact the engineering department of the respective utility prior to installation.**

## 84-024 - DISCONNECTING MEANS - GENERAL (SEE APPENDIX M)

- 1 c) Have contact operation verifiable by direct visual means if required by the supply authority.
- 1 d) Have provision for being locked in the open position.

## 84-030 - WARNING NOTICE AND DIAGRAM (SEE APPENDIX M)

A single line, permanent, legible diagram of the interconnected system shall be installed in a conspicuous place at the supply authority disconnecting means and supply authority meter location.

This diagram should show the physical location of the interconnected sources, the interlocks between the switching equipment and isolation points (utility disconnect) so that personnel are able to isolate the Section being serviced. Acceptance of the disconnect location shall be acceptable to the supply authority and a letter of acceptance should be provided upon submission of plans for review.

See Figure B64-4 in Appendix B and Rule 64-002 [Figure 64-1](#) for an illustration of an interconnected photovoltaic system.

## 2-035 – OIL AND GAS FIELD INSTALLATIONS

Installations for oil and gas fields shall comply with Section 19, *Code for Electrical Installations at Oil and Gas Facilities, Fifth Edition, 2021*, as published and distributed by TSASK. It is available on our website at [www.tsask.com](http://www.tsask.com).

## MINING INSTALLATIONS

### STANDARDS APPLICATIONS

#### Canadian Electrical Code, Part 1 C22.1 - Safety Standards for Electrical Installations

The electrical works, facilities and plant that are on surface and are used for housing, maintenance, and processing of extracted minerals.

#### M421 - Use of Electricity in Mines

Supplemental to the requirements of C22.1, including the electrical works, facilities and plant that are both underground and on surface that are used in the extraction of minerals.

*The Electrical Licensing Act, 1993 -c.E-7.2 s.8(1), 23(1)(2)(3)*

### APPROVED ELECTRICAL EQUIPMENT

- C22.1-15 2-024 - Use of Approved Equipment,
- M421 4.1.2 - Application,
- The Electrical Inspection Act, 1993 - c.E-6.3 s.18(1)(2) - Equipment Approval

All surface and sub-surface electrical equipment requires an overall approval from a Saskatchewan recognized Certification Body prior to being electrically connected or reconnected and must bear evidence of the approval or certification. See [2-024](#).

### 2-012 - NOTIFICATION OF INSPECTION

Applies to owner's new installations of cables and/or equipment, installed by employees or contractors. See [2-012](#).

### 2-014 - PLANS AND SPECIFICATIONS

Applies to owner's new installations of cables and/or equipment, installed by employees or contractors. See [2-014](#).



## 12-402 - USE OF FLEXIBLE CORD

(3) Flexible cord shall not be used (a) as a substitute for fixed wiring (i) permanently secured to any structural member. See also M421-11. 6.2.1.1.

## 36-006 - WARNING NOTICE

(1) Permanent warning notice shall be placed (b) on all high voltage cables at points of access (d) on all exposed portions of all high voltage cables at a spacing not to exceed 10 m (33').

## M421-11 4.2.1.2 MINE PLANS

Plans and diagrams shall be reviewed and updated every 4 months, and shall be posted at each power skid, electrical room, substation, load break / switch, and distribution location.

## M421-11 4.3.3.4 IDENTIFICATION OF CABLES

Each cable assembly operating at a voltage above 300 V shall be labeled:

- At the distribution / source end of the cable;
- Where the cable terminates or which equipment the cable is connected to in the field; and
- At the equipment end of the cable – the overcurrent device location for the cable and its source location.

## M421-11 6.2.1 CONDUCTORS

Cable supports shall have a safety factor of 5.

## △ APPENDIX E – DUST FREE ROOMS

See rules for Appendix J for Class II and Class III Hazardous Locations and Rule 18-008, Zones 20, 21, 22 Hazardous areas for Grain Handling. Grain Elevators, Seed Cleaning Plants and Feed Mills.

**NOTE:** This Appendix is an informative (non-mandatory) part of this Standard.

### E1 - INTRODUCTION

This Appendix covers recommended practices for the housing of electrical equipment. With respect to actual constructional requirements, it is not practical to cover all materials and methods that are or may become available and, therefore, any specific details mentioned in this Appendix are to be considered examples rather than specific requirements. The *National Building Code of Canada* or any other building code that may be in force in any particular locality should take precedence over this Appendix and should be consulted in this respect.

### E2 - SCOPE

This Appendix applies to the construction of dust-free rooms built adjacent to or as part of buildings that, by the nature of their use or occupancy, are subject to accumulations of dusts that may create a fire or explosion hazard or that may be detrimental to the proper operation of electrical equipment not provided with dust-tight enclosures.

### E3 - DEFINITION

The following definition applies in this Appendix:

**Dust-free room** — a room, building, or other area, of a size that permits the entrance of persons for operation and maintenance purposes and constructed so that the quantity of dust that can enter will not create a hazardous condition.

### E4 - USE

#### E4.1

Dust-free rooms are intended to be used to house electrical equipment except equipment required by the latest edition of the CEC to be installed in vaults.

#### E4.2

Dust-free rooms should not be used for any manufacturing, processing, maintenance, storage, or other purposes except those that may be essential for the proper operation and maintenance of the electrical equipment that they house.



## E5 - ENCLOSING OF ELECTRICAL EQUIPMENT

### E5.1

Electrical equipment in dust-free rooms need not be of types approved for Class II locations.

### E5.2

Where access to the dust-free room by unauthorized persons is permitted, the electrical equipment should be enclosed, guarded, protected, etc. as required by the latest edition of the CEC for ordinary locations.

### E5.3

Where access is to unauthorized persons only, enclosures may be omitted as provided for by the latest edition of the CEC. (E.g., Section 26).

## E6 - MATERIALS AND METHODS OF CONSTRUCTION

Materials used for the construction of dust-free rooms and the method of construction should fulfill the following conditions:

- f) the enclosure of the room should be as impervious to the passage of dust from outside the room as is practicable;
- g) the various components, walls, floors, ceilings, etc. should be capable of safely supporting the live and dead loads (including impact) to which they are liable to be subjected;
- h) there should be no likelihood that dust passages will be created due to shrinkage, breaking, or cracking;
- i) the completed structure should have a fire resistance rating of 1 h or better;
- j) in buildings constructed of non-combustible materials, the rooms should also be constructed of non-combustible material, but in other buildings, the rooms may be constructed of combustible materials with non-combustible facing on at least the inner surfaces; and
- k) if it is necessary that shafts or other rotating or sliding members be used to connect equipment outside the room with that inside, suitable means such as seals, gaskets, baffles, etc. should be provided to prevent passage of dust through the necessary openings.

## E7 - FLOORS

Some acceptable floor constructions are as follows:

- a) solid concrete slab of minimum thickness 75 mm and reinforced as necessary; or
- b) steel joists with welded plate metal floor or concrete slabs of minimum thickness 50 mm over the joists and 22 mm Portland cement plaster on metal lath under them.

Wherever necessary, floors should be surfaced with insulating material to prevent shock hazard.

## E8 - WALLS

Some acceptable wall constructions are as follows, and it is to be noted that lath and plaster on both sides must have other construction built into the wall to ensure continuance of the dust-free features, and plywood joints must be backed by studding:

- a) monolithic concrete of minimum thickness 100 mm reinforced as necessary;
- b) built-up masonry consisting of
  - i) solid bricks of minimum thickness 95 mm;
  - ii) hollow tile of minimum thickness 75 mm if plastered both sides, and 150 mm if not plastered; or
  - iii) hollow concrete or cinder concrete block of minimum thickness 125 mm if plastered both sides, and 200 mm if not plastered; or
- c) stud construction of 50 mm if of metal or 100 mm if of wood, faced on the outside with metal or perforated gypsum lath with 19 mm gypsum or 22 mm Portland cement plaster, faced on the inside with
  - i) metal-faced laminated wood;
  - ii) laminated wood with 19 mm gypsum or 22 mm Portland cement plaster on metal or perforated gypsum lath;
  - iii) laminated wood with fire-resisting non-metallic facing; or
  - iv) sheet metal equivalent to 1.69 mm (No. 14 MSG) steel with welded or riveted locked-seam joints secured to metal studs by welding or by self-locking screws.

## E9 - CEILINGS

Ceilings, if load bearing, should have the same construction as floors, but if non-load bearing, may be constructed similarly to walls with wood joists, if used, of greater depth in accordance with the span.

## E10 - CUBICLE CONSTRUCTION

### E10.1

Where the room is constructed as a free-standing cubicle with walls and ceiling not forming a part of and spaced away from the structure of the building proper, the walls and ceiling may be of sheet steel not less than 1.69 mm (No. 14 MSG) thick, suitably joined and reinforced as may be necessary.

### E10.2

If the floor is elevated above the floor of the building proper, it may be constructed in accordance with Clause [E7](#) and the plaster may be omitted.

## E11 - DOORS

### E11.1

Doors giving access to the room from dusty locations should be

- l) either metal-clad or hollow metal and weather-stripped or otherwise arranged to prevent dust leakage at the edges of frames and sills; and

m) equipped with self-closers.

### E11.2

If operation of the electrical equipment requires entry to the room from dusty locations, two hinged doors with a 1.5 m vestibule between them should be provided, but where entry is necessary for maintenance only, single doors may be used.

### E11.3

Doors giving access to the room from a dust-free atmosphere may be of ordinary types.

### E11.4

If more than one point of access to a room is provided, all but the principal one should be either securely locked or other adequate means should be used to prevent unauthorized traffic through the room.

### E11.5

All doors should be provided with means whereby they can be readily unlocked and opened from the inside without the use of a removable key.

## E12 - WINDOWS

### E12.1

Windows facing dusty locations should have a fixed metal sash and wired glass.

### E12.2

Windows in exterior walls may be arranged for opening if it is reasonably certain that the surrounding exterior area will remain sufficiently dust-free.

## E13 - VENTILATION

### E13.1

Ventilation by clean air should be adequate for the dissipation of heat from the electrical apparatus installed.

### E13.2

If ventilation is by means of forced air circulation, the air should be forced into the room rather than exhausted out of it.

### E13.3

It is recommended that the air in the room be kept at a pressure slightly above atmospheric, which will tend to blow any dust out of the room rather than have it sucked in.

### E13.4

The amount of ventilating air required is difficult to specify in an empirical value because it depends on

- n) the size of the room;
- o) the dissipating ability of walls and ceilings;
- p) the amount and nature of the electrical equipment; and
- q) the temperature of the incoming air.

### E13.5

The cooling effect may be obtained by radiation alone (if the area is sufficient), by ventilation alone, or by a combination of both.

## APPENDIX M – RENEWABLES MARKING, WARNING NOTICES AND DIAGRAMS

A warning sign for a photovoltaic system shall be in capital letters with a minimum height of 9.5mm in white on a red background.

### 64-060(10) - DISCONNECTING MEANS

- All AC disconnects with 2 sources of power.



### 64-066(1)(B) - UNGROUNDED RENEWABLE ENERGY POWER SYSTEMS

- Ungrounded DC circuits.

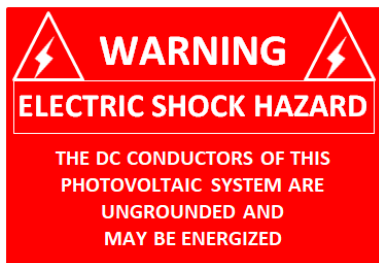

### 64-072(1) - MARKING

- For each interconnecting AC power source.



## 64-074(4) - WARNING NOTICE AND DIAGRAM

- For energy storage systems.



## 64-112(4)(B)(III) - INTERACTIVE POINT OF CONNECTION

- PV input breaker in electrical panelboard.

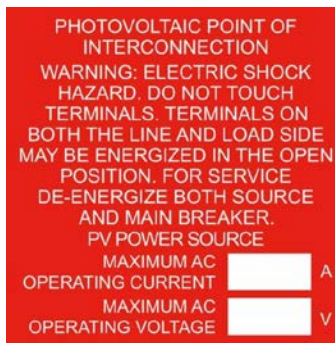

## 64-200(1) - MARKING

- String inverters - DC Disconnect.

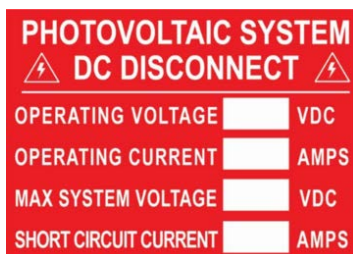

## 64-200(2) - MARKING

- When rapid shutdown is installed labelling at the DC disconnect is required.

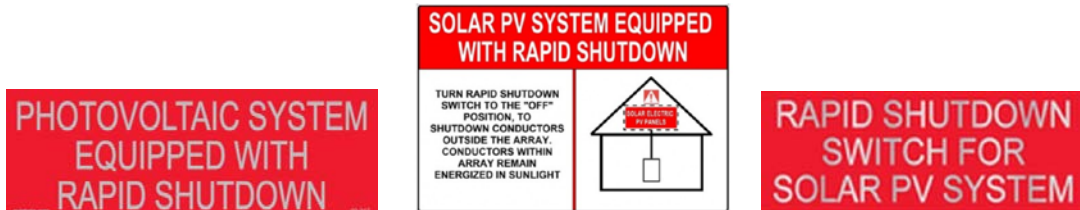

## 64-202(5)(C) - VOLTAGE OF SOLAR PHOTOVOLTAIC SYSTEMS

- For all DC circuits over 750 VDC.



## 64-218(5) - PHOTOVOLTAIC RAPID SHUTDOWN

- Rapid shutdown initiation device shall be shown on the diagram of 84-030(2).

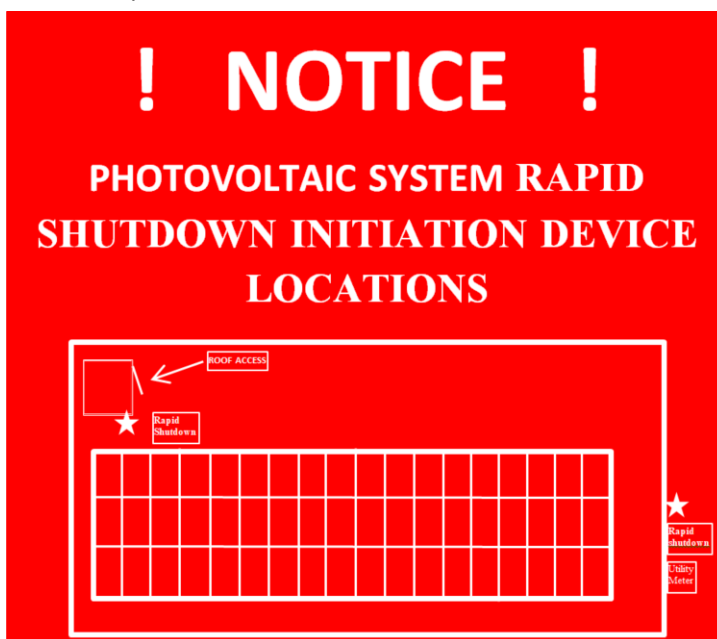

## 64-218(6) - PHOTOVOLTAIC RAPID SHUTDOWN

- Placards shall be located at the supply authority meter location and the consumer's service equipment location.

The location of these placards (or additional placards) on buildings without exterior metering may require discussion with the local fire department (e.g., near the gas meters, water standpipe, service splitter, fire annunciation panel).

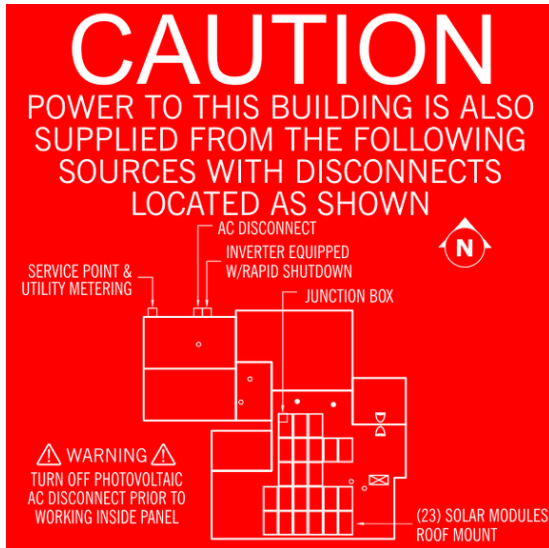

## 84-030(1) - WARNING NOTICE AND DIAGRAM

- Utility disconnect and interconnected system information at the utility disconnect and meter location.





## 84-030(2) - WARNING NOTICE AND DIAGRAM

- Single-line, permanent, legible drawing of the interconnected system, and equipment locations.

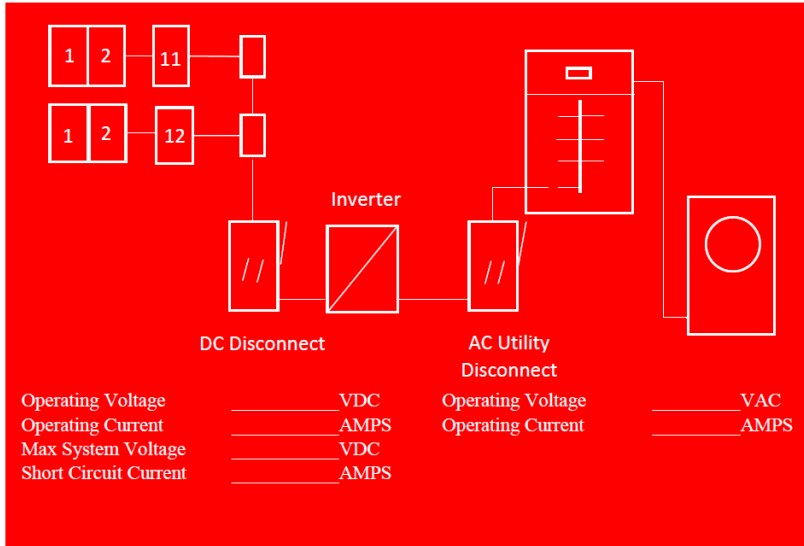

- Shall be installed at the utility disconnect and meter location.

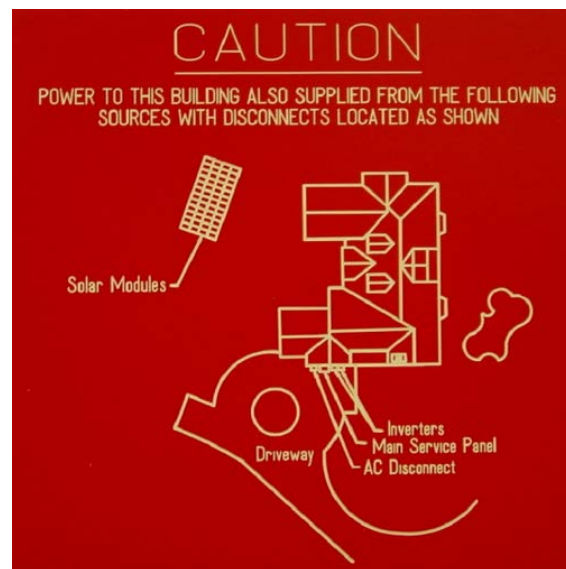
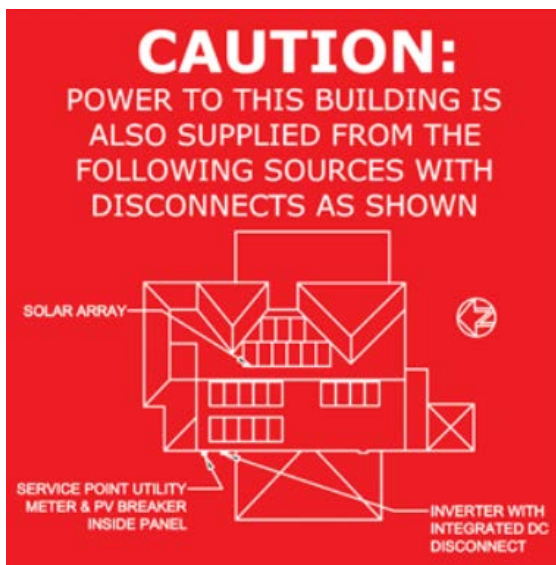

### Residential Service Customer transfer switch required.

Example with generator neutral bonded to frame  
(note 3 & 4)

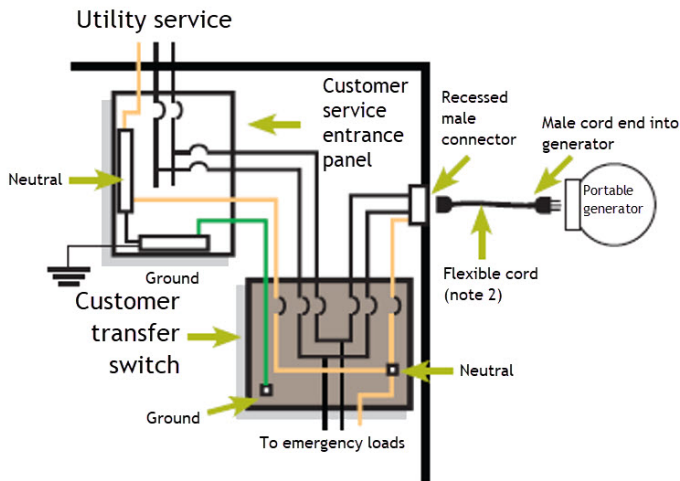

### Farm Service Using SaskPower transfer switch. Grounding / bonding (note 3)

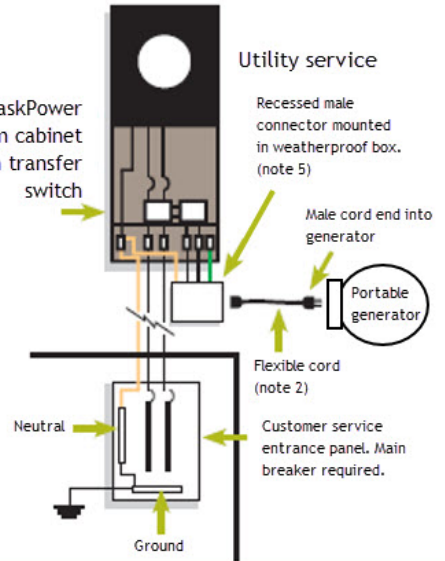

**NOTES:**

1. Rewiring or tampering with a generator unit voids CSA certification.
2. Conductors must be sized to match the maximum output of the generator.
3. Follow generator manufacturer's installation, grounding, and operation instructions.
4. A transfer switch must be capable of switching the neutral when the generator neutral is bonded to the frame.
5. Permission is required from your local **SaskPower District Office** to install this recessed male connector on a transformer pole.
6. A portable electric power plant that is operated at voltages exceeding 240 volts to ground or is rated in excess of 12.0 kW shall be grounded as per Section 10 of the current CEC.

**PORTABLE ELECTRIC POWER PLANTS (AS PER OH&S REGULATIONS 1996)**

- 460(1) An employer, contractor or supplier shall ensure that:
- (a) a portable electric power plant that is operated at voltages exceeding 240 volts to ground or is rated in excess of 12.0 kilovolt-amperes is connected to ground in a manner approved pursuant to *The Electrical Inspection Act, 1993*; and
  - (b) all electrical equipment connected to an ungrounded portable electric power plant:
    - (i) is of the double insulated type; and
    - (ii) is clearly marked as being of the double insulated type or is supplied from a Class A type ground fault interrupting device.

### Farm Service Using customer transfer switch Example with neutral floating (note 3)

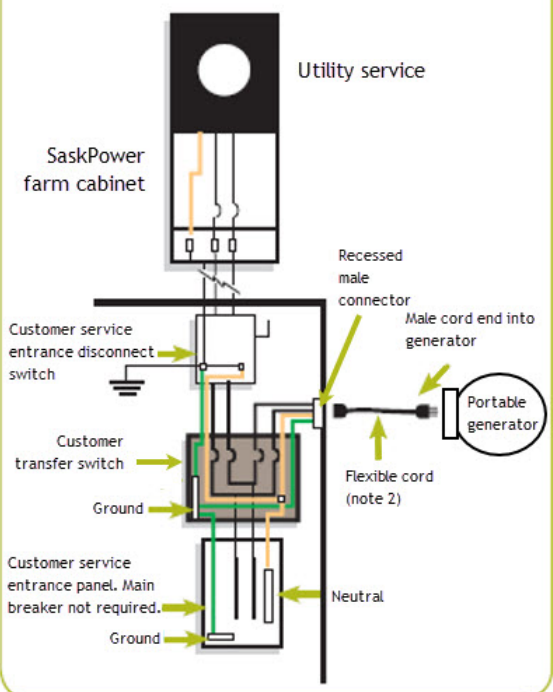

## Annex B

**TO:** The Electrical Code Coordinator for the Saskatchewan Electrical Interpretations

**FROM:**

**AFFILIATION:**

**DATE:**

**RE:** Request for an amendment to Rule(s)

---

Request (Specifically Worded):

Reason for Request:

Supporting Information:

**For office use only:**

**Subject No. Assigned:**

***Completed form to be sent to: Saskatchewan Interpretations Code Coordinator – [geis@tsask.ca](mailto:geis@tsask.ca)***

**Submitter:**





## Appendix of Amendments:

### September 1, 2023:

1. Pages 16, 17, & 19: added requirements for Inspections Requests, and Plans Submission for Marinas and similar facilities.
  - Ensures electrical safety in these critical installations
2. Page 20: amended requirements for permitting/upgrading requirements for flood/fire damaged installations.
  - Clarified requirements
3. Page 21: added note to Renovation of Existing Installations which puts onus on contractor to ensure branch circuits are safe when replacing a service.
  - Ensures homeowner safety after service replacement.
4. Page 22: added load calculation requirements when adding loads to installations.
  - Ensures service size and loading is considered
5. Page 27: changed 2-400 – only weatherproof connectors are allowed in underside of all equipment outdoors.
  - Departmental decision
6. Page 38: removed information item 6-408(1)(F) regarding location of meters. (and corresponding reference on page 27, 2-238)
  - Enforcement by Utility, no longer required as an Information Item by Electrical Inspections
7. Page 48: changed entire wording of 10-604.
  - Clarified requirements
8. Page 50: added bonding of temporary structures to 10-700.
  - Added requirements to increase public safety at events
9. Page 50: added clarification, links, and diagram to 12-012(13) regarding burial of electrical in proximity to gas.
  - Simplifies and clarifies
10. Page 54: corrected typo in Example calculation – 0.520 to 0.0520.
  - General housekeeping
11. Page 74: added “indoor” & “mobility” to the AFCI/GFCI relaxation for lifts.
  - Ensures no stranding of people while lifts are being used
12. Page 85: relabeled renewable energy diagrams to reflect current applicable code rules.
  - General housekeeping
13. Page 89: changed “accessible to public” height from 2.5 m to 3m.
  - Conformity with other CEC rules regarding inaccessible
14. Page 89: added “mechanical protection” for solar cabling.
  - Clarified requirements
15. Page 99: added construction requirements to long-term temporary services.
  - Ensures public safety/installation integrity
16. Pages 113-114: revamped genset connection pictures.
  - General housekeeping of blurry drawings
17. Page 113: added “Ground Fault Interrupting Device” to complete final sentence on page 113
  - General housekeeping



June 15, 2022:

1. Cover Page: added Version number (V3.0) and Amended date.
  - Ease of Interpretation Version identification.
2. Page 12: removed dollar values for Bond Admin Fees and Unreported work penalties.
  - Fees and Rates should be referenced from other TSASK official documents.
3. Page 14: removed dollar values for Permit fines.
  - Fees and Rates should be referenced from other TSASK official documents.
4. Page 16: 2-004 Permits for signs and outline lighting changed to reference Electrical Fee Schedule
  - Ensures alignment with Electrical Fee Schedule and any changes that may occur going forward.
5. Page 16: 2-004 Permits for customer supplied equipment and skids changed reference to [Electrical Fee Schedule](#).
  - General housekeeping.
6. Page 17: Change 2-014(1)(e) from 750V to 1000V.
  - Alignment with CEC and Electrical Fee Schedule.
7. Page 18: Change 2-014(2)(f) from 750V to 1000V.
  - Alignment with CEC and Electrical Fee Schedule.
8. Page 20: removed dollar values for Plans Review Fees.
  - Fees and Rates should be referenced from other TSASK official documents.
9. Page 52: removed interpretation on 12-608.
  - Bonding of armoured cables shall be as per CEC 12-608, 4-004, & 4-008.
10. Page 79: 34-000 Scope for signs and outline lighting changed to reference Electrical Fee Schedule
  - Ensures alignment with Electrical Fee Schedule and any changes that may occur going forward.
11. Page 117: added Appendix of Amendments.
  - Allows record of changes.



April 7, 2022:

1. Page 14: Removed “Commencement of work” note.
  - Departmental decision to remove.
2. Page 15: added 2-004 Permits for low voltage and extra low voltage installations.
  - Was a previous omission.
3. Page 20: 2-022 amended note on round meter bases from “isolate” to “terminate and ground”.
  - Was a previous omission.
4. Page 43: 10-210 bullet 1 changed wording to “To meet the intent of 10-002 in establishing equipotentiality between bonded equipment and the nearby surfaces of the earth, there shall be an electrode installed and grounding conductor connected to the non-current carrying parts of electrical equipment at all facilities, buildings, or structures supplied with electrical panels or sub-panels power. See [Figure 10-2](#).”
  - Wording better addresses the issue of equipotential bonding, further clarifying the requirements of the Department.
5. Page 79: Removed all reference to Section 30.
  - Aligns with CEC removal of 30-500 (Luminaries in buildings of residential occupancy) in 2021
6. Page 81: Amended last sentence from “column 2 of Table 2” to “75°C column of Table 2”.
  - Was a previous omission.
7. Page 93: added “S” to “ECTION 68 – POOLS, TUBS, AND SPAS”.
  - Housekeeping.



